

# SQ, SQ-N, SQE, SQE-N

Submersible pumps  
50/60 Hz



# Contents

## General data

Performance range	3
SQ submersible pumps	4
Pump and motor range	4
Pipe connection	4
Type key	4
Pumped liquids	4
Operating conditions	4

## Features and benefits

Dry-running protection	5
Protection against upthrust	5
Overvoltage and undervoltage protection	6
Variable speed	7

## Application examples

SQ with pressure switch and pressure tank	8
SQ with Presscontrol (with/without pressure tank)	9
Constant-pressure control with CU 301 - residential water supply	10
Constant-pressure control with CU 301 - irrigation	11
Maintaining a constant water table	12
Emptying or filling a tank	13
Pumping from one tank to another	14
Workshop setting of operating parameters	15
SQE with manual speed control	16
Replacement in existing installation	17

## Communication, CU 301

CU 301, control unit	18
R100 menu structure for the CU 301	19
R100 menus for CU 301	20

## Communication, CU 300

CU 300 Control unit	21
R100 menu structure for the CU 300	22
R100 menus for CU 300	23
Examples of R100 displays	24
Alarm indication	25
Benefits of CU 300/R100	25

## Pump selection

Determining head and flow	26
Pump sizing	27
Variable speed	28
Curve conditions	28
Selecting the right pump for the SQE constant-pressure system	29
Selection of pressure tank	30

## Performance curves/ Technical data

SQ 1, SQ 1-N, SQE 1, SQE 1-N	32
SQ 2, SQ 2-N, SQE 2, SQE 2-N	34
SQ 3, SQ 3-N, SQE 3, SQE 3-N	36
SQ 5, SQ 5-N, SQE 5, SQE 5-N	38
SQ 7, SQ 7-N, SQE 7, SQE 7-N	40

## Technical data

Pump, SQ and SQE	42
Control units, CU 300 and CU 301	42
Material specification (Pump)	43
Material specification (Motor)	43
Wiring diagrams	44
Electrical connection of CU 300	44
Electrical connection of CU 301	45

## Accessories

Constant-pressure packages incl. pump	46
Constant-pressure package excl. pump CU 301	46
Pressure sensor for CU 301	46
CU 300	46

## Order data

Complete units 1 x 200-240 V with 1.5 m cable	51
Submersible drop cables	53

## Performance range

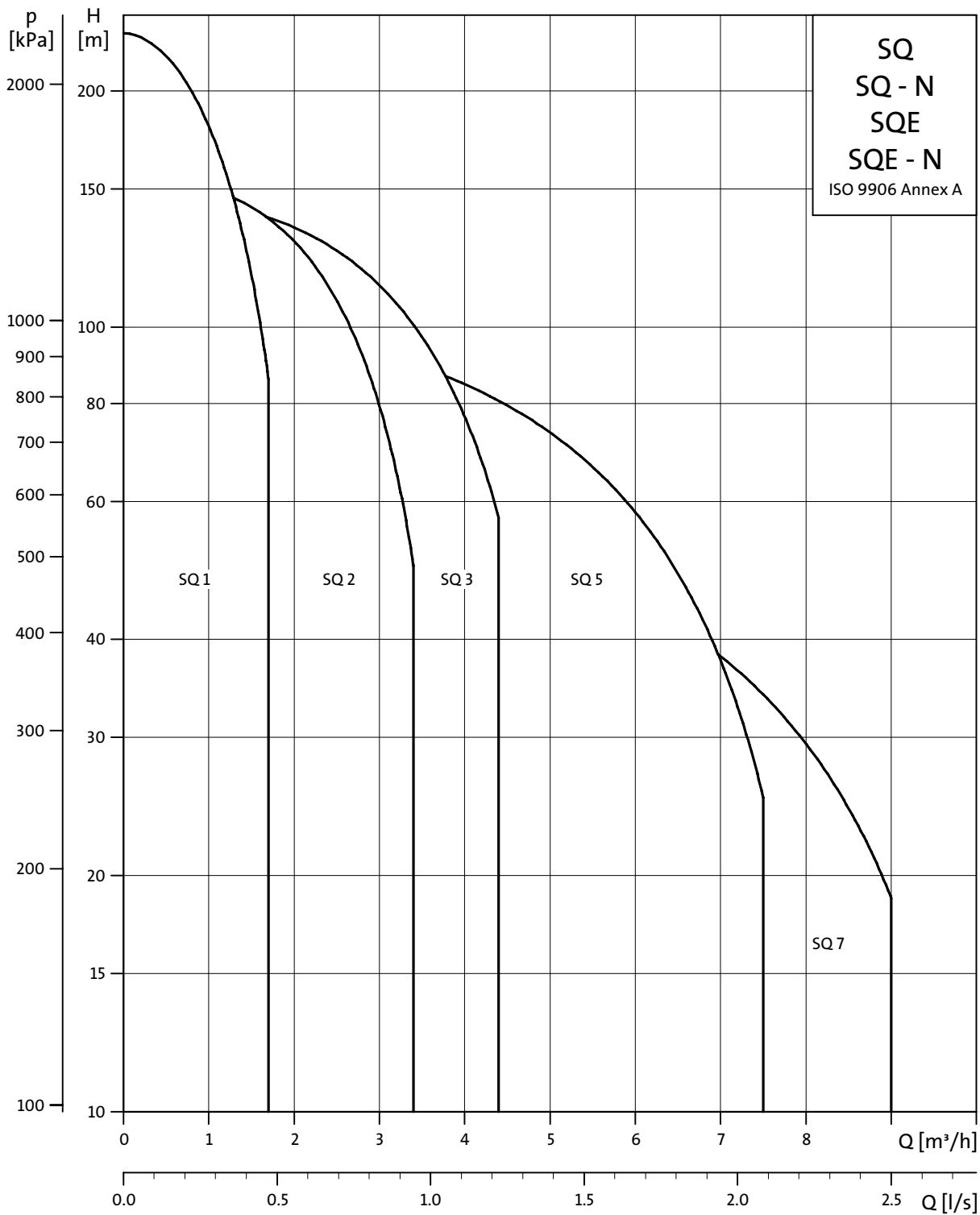

TM02 9976 4104

## SQ submersible pumps

SQ pumps are suitable for both continuous and intermittent operation for a variety of applications:

- Domestic water supply
- Small waterworks
- Irrigation
- Tank applications
- Pressure boosting.

**Note:** For other applications, please contact Grundfos.

SQ pumps offer the following features:

- Dry-running protection
- High efficiency of pump and motor
- Wear resistance
- Protection against upthrust
- Soft starter
- Overvoltage and undervoltage protection
- Overload protection
- Overtemperature protection.

Additionally the SQE pumps offer:

- Variable speed
- Electronic control and communication.

The SQ pump is a submersible pump which is available in four different versions:

- SQ
- SQ-N
- SQE
- SQE-N.

The motors are based on the most recent technology within permanent magnets. This technology is the main reason for the high efficiency of the motors. The motors have a built-in electronic unit containing a frequency converter featuring soft start.

The SQ pump is fitted with a single-phase Grundfos MS 3 or MS 3-NE motor and by means of the built-in frequency converter it is driven at a constant speed.

The SQE pump is fitted with a single-phase Grundfos MSE 3. The MSE 3 motor can communicate with the Grundfos control units CU 300 and CU 301, which can be operated by means of Grundfos remote control R100.

The SQE pump features variable speed which is offered through frequency control. As a consequence, the pump can be set to operate in any duty point in the range between the pump min. and max. performance curves.

The CU 301 is specially developed for applications where a constant pressure is needed.

The SQE pump can operate without the CU 300 or the CU 301. However, in this situation it will not offer all the features available when the pump is connected to a CU 300 or CU 301. The CU 300 and CU 301 provide full control of the SQE pumps. In case of a pump fault, an alarm will be indicated on the front of the CU 300 or CU 301. The R100 enables monitoring of the installation and changing of the factory settings.

## Pump and motor range

Product	Description	Material
SQ pump	(1, 2, 3, 5, and 7 m <sup>3</sup> /h)	Stainless steel DIN 1.4301, AISI 304
SQ-N pump	(1, 2, 3, 5, and 7 m <sup>3</sup> /h)	Stainless steel DIN 1.4401, AISI 316
MS 3 motor	Single-phase Max. 1.85 kW	Stainless steel DIN 1.4301, AISI 304
MS 3-NE motor	Single-phase Max. 1.85 kW	Stainless steel DIN 1.4401, AISI 316
MSE 3 motor	Single-phase Max. 1.85 kW	Stainless steel DIN 1.4301, AISI 304
MSE 3-NE motor	Single-phase Max. 1.85 kW	Stainless steel DIN 1.4401, AISI 316

## Pipe connection

Pump type	Threaded connection
SQ 1, SQ 2, SQ 3	Rp 1½
SQ 5, SQ 7	Rp 1½

## Type key

Example	SQ	E	2	-55
Type range				
Blank = Basic version				
E = Electronic control and communication				
Rated flow (in m <sup>3</sup> /h)				
Head at rated flow (in m)				
Material code:				
Blank = Stainless steel DIN W.-nr. 1.4301				
N = Stainless steel DIN W.-nr. 1.4401				

## Pumped liquids

SQ and SQE pumps are designed for pumping thin, clean, non-aggressive and non-explosive liquids, not containing solid particles or fibres. SQ and SQE are suitable for pumping liquids with a content of sand up to 50 g/m<sup>3</sup>. A higher content of sand will shorten pump life.

## Operating conditions

### Liquid temperature:

Flow velocity past motor	Max. liquid temperature
0.0 m/s (Free convection)	30°C
Min. 0.15 m/s	40°C

## Dry-running protection

The SQ and SQE pumps are protected against dry running. A value of  $P_{\text{cut-out}}$  ensures cut-out of the pump in case of lack of water in the borehole thus preventing a burnout of the motor.

$P_{\text{cut-out}}$  is factory-set both for the SQ and SQE pump.

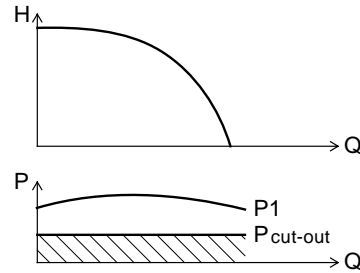

TM01 2751 2298

## High pump efficiency

The hydraulic pump components are polyamide reinforced with 30% glass fibre. The hydraulic design gives high pump efficiency meaning low energy consumption and therefore low energy costs.

## High motor efficiency

All four motor versions are based on a permanent magnet rotor (PM motor) featuring high efficiency within a wide load range.

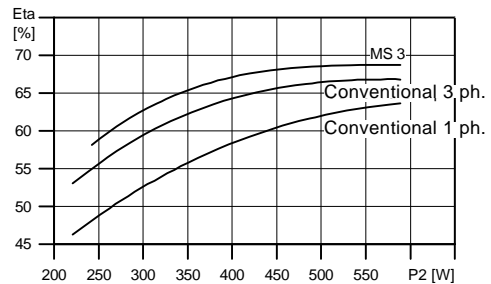

TM01 2698 2298

## Wear resistance

The SQ pump design features impellers which are not fastened to the shaft ("floating"). Each impeller has its own tungsten carbide/ceramic bearing. The construction and the used materials ensure high wear resistance to sand for long product life.



TM01 3141 3498

## Protection against upthrust

Starting up a pump with a very low counter pressure involves the risk of the entire impeller stack being lifted - also called upthrust. Upthrust may cause breakdown of both pump and motor.

The three motor versions are fitted with a top bearing protecting both pump and motor against upthrust and thus preventing breakdown during the critical start-up phase.

## Excellent starting capabilities

The integrated electronic unit of the motor features soft starting. Soft start reduces the starting current and thus gives the pump a smooth and steady acceleration.

The soft starter minimizes the risk of wear of the pump and prevents overloading of the mains during start-up.

The excellent starting capabilities are a result of the high locked-rotor torque of the permanent magnet motor together with the few pump stages. The high starting reliability also applies in case of low voltage supply.

## Overvoltage and undervoltage protection

Overvoltage and undervoltage may occur in case of unstable voltage supply.

The integrated protection of all three motor versions prevents damage to the motor in case the voltage moves outside the permissible voltage range.

The pump will be cut out if voltage falls below 150 V or rises above 315 V. The motor is automatically cut in again when the voltage is again within the permissible voltage range. Therefore no extra protection relay is needed.

## Overload protection

Exposure of the pump to heavy load causes the current consumption to rise. The motor will automatically compensate for this by reducing the speed to 3000 rpm. Further overload will lead to stop.

If the rotor is being prevented from rotating this will automatically be detected and the power supply cut out. Consequently, no extra motor protection is needed.

## Overtemperature protection

A permanent magnet motor gives off very little heat to its surroundings. In combination with an efficient internal circulation system leading the heat away from the rotor, stator and bearings, this fact ensures optimum operating conditions for the motor.

As an extra protection, the electronic unit has a built-in temperature sensor. When the temperature rises too high, the motor is cut out; when the temperature has dropped, the motor is automatically cut in again.

## Reliability

The motors have been constructed with a view to high reliability and have the following features:

- Tungsten carbide / ceramic bearings.
- Thrust bearings protecting against downthrust.
- Product life time equal to conventional AC motors.

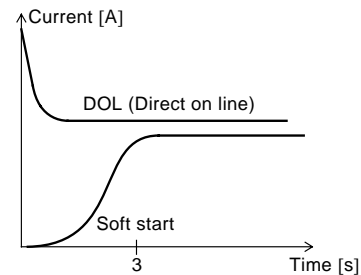

TM01 3479 4198

## Variable speed

The MSE 3 motor enables continuously variable speed control within the 3000 and 10700 rpm. The pump can be set to operate in any duty point in the range between the 3000 and 10700 rpm performance curves of the pump. Consequently, the pump performance can be adapted to any specific requirement.

The variable speed control facility requires the use of the CU 300 or CU 301 control unit and the R100. See page 28.

For the calculation of pump speed the program "SQE Speed Calculation" is available on CD-ROM as an accessory, see page 49. On the basis of a required head and flow the speed of the motor is calculated. Furthermore, the specific pump performance curve can be illustrated.

## Installation

The SQ and SQE may be installed vertically, horizontally or in any position inbetween.

**Note:** The pump must not fall below the horizontal level in relation to the motor.

The following features ensure simple installation of the SQ and SQE pumps:

- Built-in non-return valve with spring,
- low weight ensuring user-friendly handling,
- installation in 3" or larger boreholes,
- only on/off switch is needed, which means that no extra motor starter / starter box is necessary, and
- SQE available with cable with a motor plug (up to 100 m).

For horizontal installation a flow sleeve is recommended in order to

- ensure sufficient flow velocity past the motor and thus provide sufficient cooling,
- prevent motor and electronic unit from being buried in sand or mud.

## Service

The modular pump and motor design facilitates installation and service. The cable and the plug are fitted to the pump with screws which enables replacement.

## Example: SQE

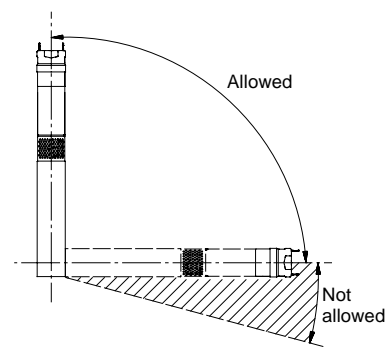

TM01 1375 1498

## SQ with pressure switch and pressure tank

SQ is ideally suited for domestic water supply in single-family dwellings or summer cottages which are not connected to municipal waterworks. SQ is easy to install and operate.

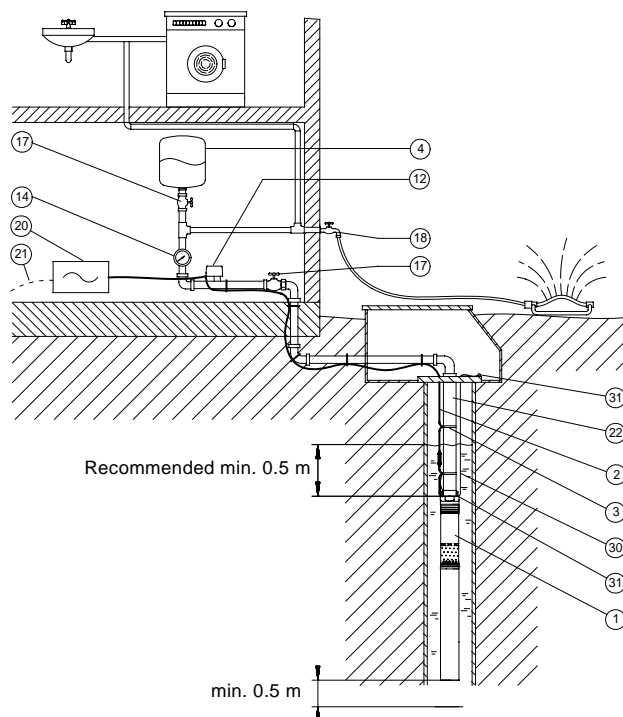

- 1 Pump, SQ
- 2 Cable
- 3 Cable clips
- 4 Pressure tank\*
- 12 Pressure switch
- 14 Pressure gauge
- 17 Isolating valve
- 18 Tap
- 20 Mains switch
- 21 Mains connection, 1 x 200-240 V, 50/60 Hz
- 22 Riser pipe
- 30 Straining wire
- 31 Wire clamp

\* For selection of pressure tank see page 47.

TM01 2447 1798

## SQ with pressure switch and pressure tank

Pos.	Part	Type	No. of units	Product number	Unit price	Total price
1	Pump, SQ					
2	Cable					
3	Cable clips					
4	Pressure tank					
12	Pressure switch					
14	Pressure gauge					
20	Mains switch					
30	Straining wire					
31	Wire clamp					



## SQ with Presscontrol (with/without pressure tank)

### Functioning and benefits

If water is consumed the SQ pump is cut in via the Presscontrol. The pressure tank is fitted between the SQ and the Presscontrol. In an installation with a pressure tank, water is supplied as soon as the tap is opened. It means that the pressure tank takes over water supply during the smooth start up of the SQ pump (about 3 seconds).

When the water consumption stops (flow = 0), the pump will continue operating for 10 seconds building up pressure in the pressure tank.

In the case of leakage with less than 50 l/hour the pump is not put into operation by the Presscontrol flow switch but by the pressure switch (Presscontrol PC 15, switch-on pressure = 1.5 bar). In case the water consumption is higher than 50 l/hour, the pump will be in continuous operation.

The setting of the pressure tank precharge pressure depends on the water level (difference of height between water level and the Presscontrol).

The setting of the flow pipe pressure at the pressure tank depends on the water level (difference of height between water level and Presscontrol) according to the following table:

Difference of height [m]	Flow pipe pressure in pressure tank [bar]
0	1.22
10	1.0
20	0.77
30	0.56

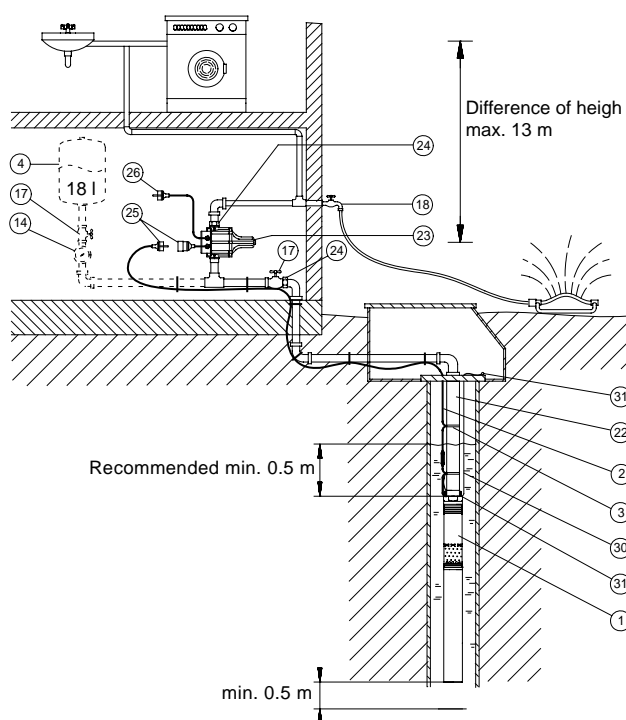

- 1 Pump, SQ
- 2 Cable
- 3 Cable clips
- 4 Pressure tank
- 14 Pressure gauge
- 17 Isolating valve
- 18 Tap
- 22 Riser pipe
- 23 Presscontrol PC 15 available with/without plug
- 24 Union
- 25 Plug
- 26 Mains connection, 1 x 200-240 V, 50/60 Hz for PC 15
- 30 Straining wire
- 31 Wire clamp

**Note:** For the Presscontrol: Back-up fuse max. 10 A.  
System pressure max. 10 bar.  
The following pump types can be used:  
SQ 1-65, SQ 1-80, SQ 2-35, SQ 2-55,  
SQ 2-70, SQ 2-85, SQ 3-40, SQ 3-55,  
SQ 3-65, SQ 3-80.

The installation has to be designed for maximum pump pressure.

Do not install draw-off points between the pump and the Presscontrol.

TM01 2987 2898

## SQ with Presscontrol (with/without pressure tank)

Pos.	Part	Type	No. of units	Product number	Unit price	Total price
1	Pump, SQ					
2	Cable					
3	Cable clips					
4	Pressure tank	18 litres				
14	Pressure gauge					
23	Presscontrol					
30	Straining wire					
31	Wire clamp					

## Constant-pressure control with CU 301 - residential water supply

### Features and benefits

The system maintains a constant pressure within the maximum pump performance in spite of a varying water consumption.

The pressure is registered by the pressure sensor and transmitted to the CU 301. The CU 301 adjusts the pump performance accordingly.

### Function

When a tap is opened the pressure in the 8 l tank will start to drop.

At low flow, lower than approximately 0.18 m<sup>3</sup>/h, the pressure will drop slowly. When the pressure in the tank is 0.5 bar below setpoint, the pump will start. The pump will run until the pressure is 0.5 bar above setpoint. This way of operation is called on/off operation.

At flow higher than approximately 0.18 m<sup>3</sup>/h the pressure will drop quickly and the pump will start immediately and maintain constant pressure.

During operation the CU 301 will regulate the pump speed to maintain a constant pressure. If there is no consumption, the pump will fill up the tank and stop after a few seconds.

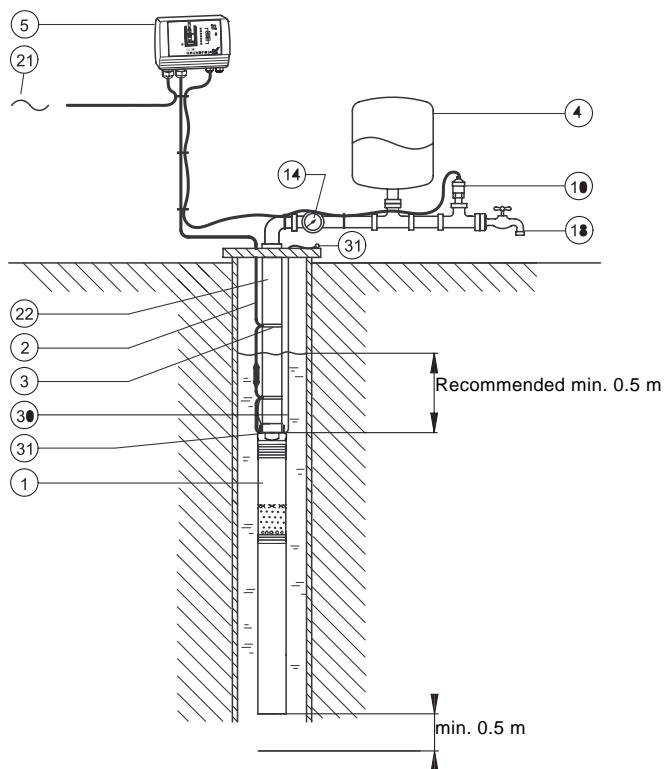

- 1 Pump, SQE
- 2 Cable
- 3 Cable clips
- 4 Pressure tank, 8 litres
- 5 Control unit, CU 301
- 10 Pressure sensor, 0-6 bar
- 14 Pressure gauge
- 18 Tap
- 21 Mains connection, 1 x 200-240 V, 50/60 Hz
- 22 Riser pipe
- 30 Straining wire
- 31 Wire clamp

If a higher constant pressure (max. 10 bar) is required use CU 300, pressure sensor and flow switch, see page 12.

TM03 3429 0406

## Constant pressure control with CU 301 - residential water supply

Pos.	Part	Type	No. of units	Product number	Unit price	Total price
1	Pump, SQE					
2	Cable					
3	Cable clips					
4	Pressure tank	8 litres				
5	Control unit	CU 301				
10	Pressure sensor					
14	Pressure gauge					
30	Straining wire					
31	Wire clamp					

## Constant-pressure control with CU 301 - irrigation

### Features and benefits

The system maintains a constant pressure within the maximum pump performance in spite of a varying water consumption.

The pressure is registered by means of the pressure sensor and transmitted to the CU 301. The CU 301 adjusts the pump performance accordingly.

### Function

When the sprinkler system is on, the pressure in the 8 l tank will start to drop.

At low flow, lower than approximately  $0.18 \text{ m}^3/\text{h}$ , the pressure will drop slowly. When the pressure in the tank is 0.5 bar below setpoint, the pump will start. The pump will run until the pressure is 0.5 bar above setpoint. This way of operation is called on/off operation.

At flow higher than approximately  $0.18 \text{ m}^3/\text{h}$  the pressure will drop quickly and the pump will start immediately and maintain constant pressure.

During operation the CU 301 will regulate the pump speed to maintain a constant pressure. If there is no consumption, the pump will fill up the tank and stop after a few seconds.

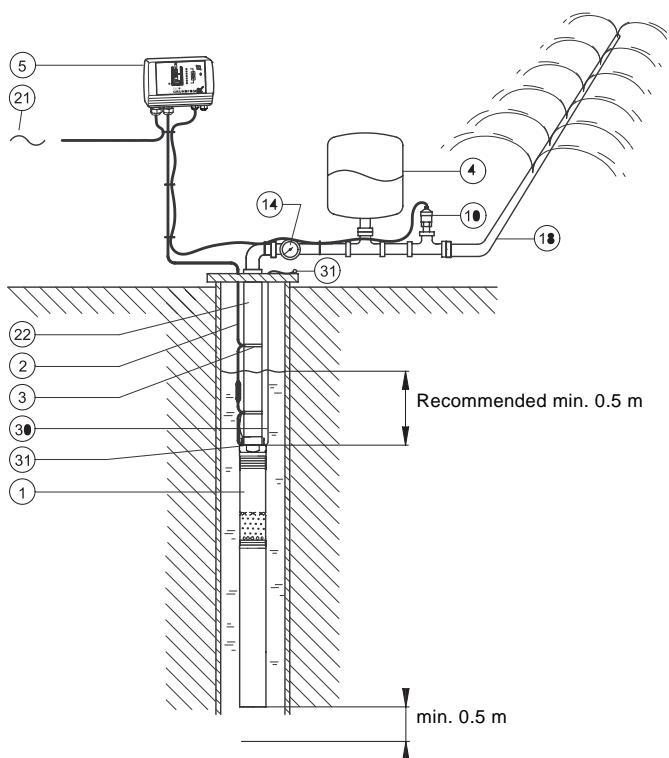

- 1 Pump, SQE
- 2 Cable
- 3 Cable clips
- 4 Pressure tank, 8 litres
- 5 Control unit, CU 301
- 10 Pressure sensor, 0-6 bar
- 14 Pressure gauge
- 18 Sprinkler system
- 21 Mains connection, 1 x 200-240 V, 50/60 Hz
- 22 Riser pipe
- 30 Straining wire
- 31 Wire clamp

If a higher constant pressure (max. 10 bar) is required use CU 300, pressure sensor and flow switch, see page 12.

TM03 3428 0406

## Constant pressure control with CU 301 - irrigation

Pos.	Part	Type	No. of units	Product number	Unit price	Total price
1	Pump, SQE					
2	Cable					
3	Cable clips					
4	Pressure tank	8 litres				
5	Control unit	CU 301				
10	Pressure sensor					
14	Pressure gauge					
30	Straining wire					
31	Wire clamp					

## Maintaining a constant water table

### Functioning and benefits

A constant water table can be maintained by adjusting pump performance. It may be important to maintain a constant water table e.g. in connection with keeping out the groundwater of a building site or preventing the penetration of salt water into a borehole containing potable water.

The example shows how to maintain a constant water table by adjusting pump performance.

### Sensors:

Level	Description	Reaction
<b>Level sensor (pos. 11)</b>		
Warning (Max.)	Too high water level. Possible cause: Insufficient pump capacity.	Alarm relay operates.
Desired level	The water level which should be maintained.	
Warning (Min.):	Too low water level. Possible cause: Too high pump capacity.	Alarm relay operates.

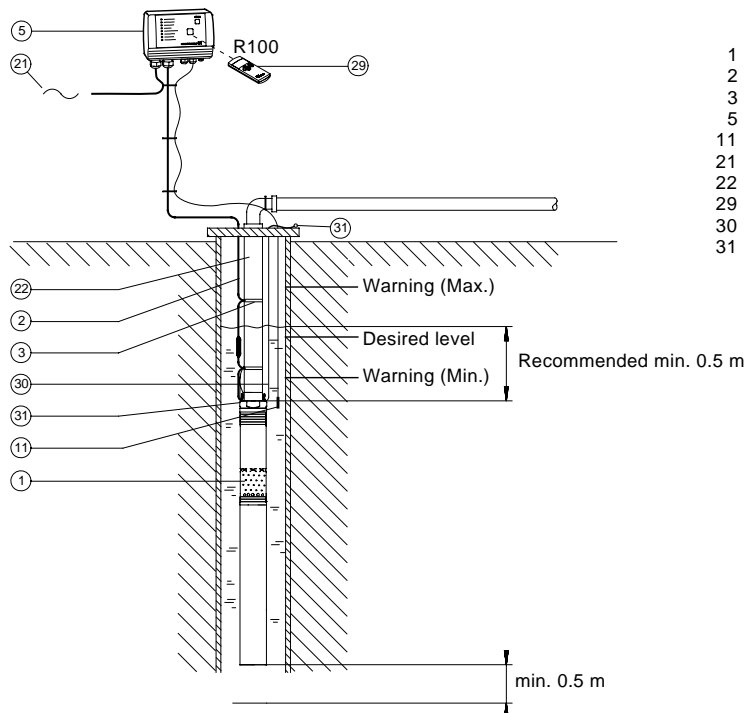

- 1 Pump, SQE
- 2 Cable
- 3 Cable clips
- 5 Control unit, CU 300
- 11 Level sensor
- 21 Mains connection, 1 x 200-240 V, 50/60 Hz
- 22 Riser pipe
- 29 Remote control, R100
- 30 Straining wire
- 31 Wire clamp

TM01 2459 4801

## Maintaining a constant water table

Pos.	Part	Type	No. of units	Product number	Unit price	Total price
1	Pump, SQE					
2	Cable					
3	Cable clips					
5	Control unit	CU 300				
11	Level sensor					
29	Remote control	R100				
30	Straining wire					
31	Wire clamp					

## Emptying or filling a tank

The SQE pump with CU 300 are ideal for emptying or filling a tank.

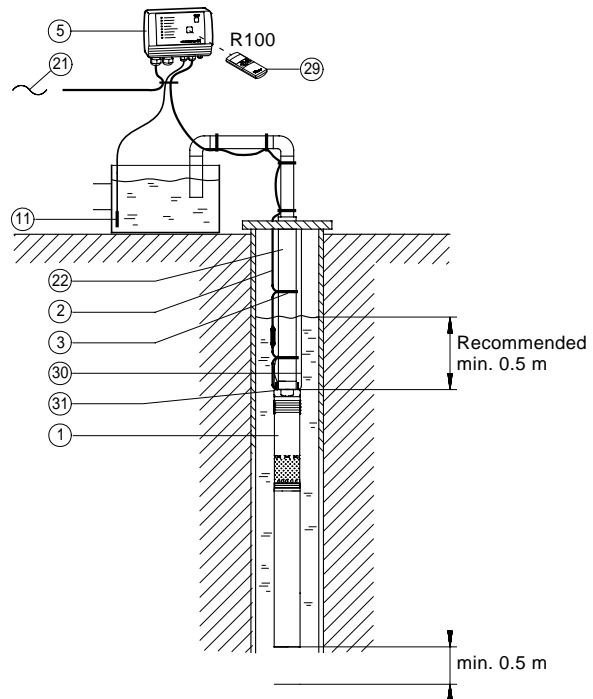
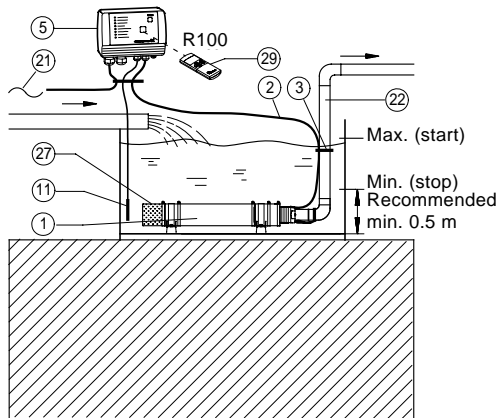

- 1 Pump, SQE
- 2 Cable
- 3 Cable clips
- 5 Control unit, CU 300
- 11 Level sensor
- 21 Mains connection, 1 x 200-240 V, 50/60 Hz
- 22 Riser pipe
- 27 Flow sleeve with strainer and supporting brackets
- 29 Remote control, R100
- 30 Straining wire
- 31 Wire clamp

TM01 8649 4801

## Emptying or filling a tank

Pos.	Part	Type	No. of units	Product number	Unit price	Total price
1	Pump, SQE					
2	Cable					
3	Cable clips					
5	Control unit	CU 300				
11	Level sensor					
22	Riser pipe					
27	Flow sleeve with strainer and supporting brackets.					
29	Remote control	R100				
30	Straining wire					
31	Wire clamp					

## Pumping from one tank to another

### Functioning and benefits

The SQE pump is ideal for pumping water from one tank to another.

### Sensors:

Level	Description	Light indication on CU 300
<b>Level sensor (pos. 11, tank at top)</b>		
Max. (stop)	When the water has reached this level, the pump stops.	Green indicator light in on/off button is flashing.
Min. (start)	When the water has dropped to this level, the pump starts.	Green indicator light in on/off button is permanently on.
<b>Level sensor (pos. 11, tank at bottom)</b>		
Max. (start)	When the water has reached this level, the pump starts.	Green indicator light in on/off button is on.
Min. (stop)	When the water has dropped to this level, the pump stops.	Green indicator light in on/off button is flashing.

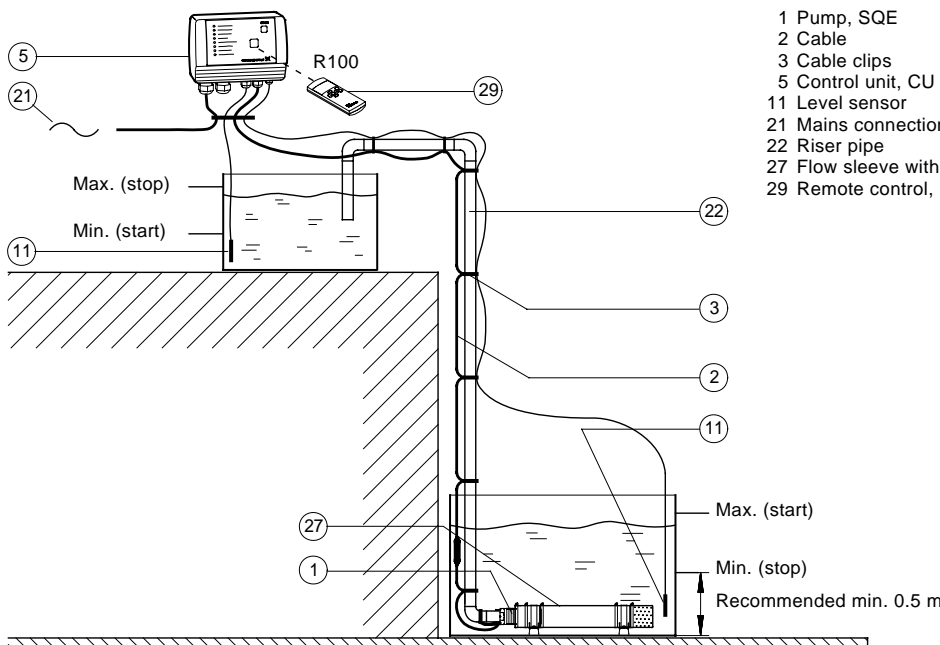

- 1 Pump, SQE
- 2 Cable
- 3 Cable clips
- 5 Control unit, CU 300
- 11 Level sensor
- 21 Mains connection, 1 x 200-240 V, 50/60 Hz
- 22 Riser pipe
- 27 Flow sleeve with strainer and supporting brackets
- 29 Remote control, R100

TM01 2454 4801

## Pumping from one tank to another

Pos.	Part	Type	No. of units	Product number	Unit price	Total price
1	Pump, SQE					
2	Cable					
3	Cable clips					
5	Control unit	CU 300				
11	Level sensor					
27	Flow sleeve with strainer and supporting brackets					
29	Remote control	R100				

## Workshop setting of operating parameters

Using the R100 and the CU 300 enables change of the motor speed in a workshop and thereby setting of the pump to a specific performance.

A program called "SQE Speed Calculation" has been developed for the calculation of the speed in order to obtain the required flow rate and head.

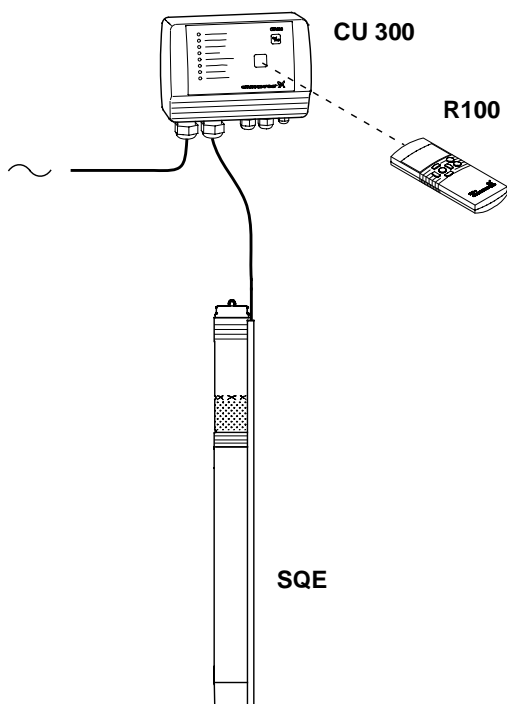

## Dry-running protection

The value  $P_{\text{cut-out}}$ , ensuring dry-running protection, is factory-set for the SQE pump.

If the speed of the SQE pump is reduced by more than  $1000 \text{ min}^{-1}$  the  $P_{\text{cut-out}}$  value must be readjusted by means of the CU 300 and R100.

**Note:** The SQE pump must not be started until the pump has been completely submerged below the water table. However the change of the motor speed can be made even if the pump is not running.

TM01 8650 4801

## Workshop setting of operating parameters

Part	Type	No. of units	Product number	Unit price	Total price
Pump, SQE					
Remote control	R100				
Control unit	CU 300				
SQE Speed Calculation program					

## SQE with manual speed control

### Functioning and benefits

Manual speed control of the SQE pumps is possible by means of R100 and an SPP 1 potentiometer.

This application is especially suitable for sampling from groundwater monitoring wells. The monitoring well is purged at high speed and the sample is taken at a low speed (quiet flow). For contaminated groundwater the SQE-NE type range is recommended.

In case frequent sampling is required, dedicated installation of the pump is recommended, thus eliminating wear caused by frequent assembly and dismantling the installation.

Furthermore, dedicated installations saves the costs of assembling and dismantling the installation.

**Important:** Through dedicated installation the transfer of contamination from one monitoring well to another is avoided.

### Dry-running protection

The value  $P_{cut\ out}$ , ensuring dry-running protection, is factory-set for the SQE pump. If the speed of the pump is reduced more than 1,000 rpm, the value of  $P_{cut\ out}$  must be readjusted by means of CU 300 and R100.

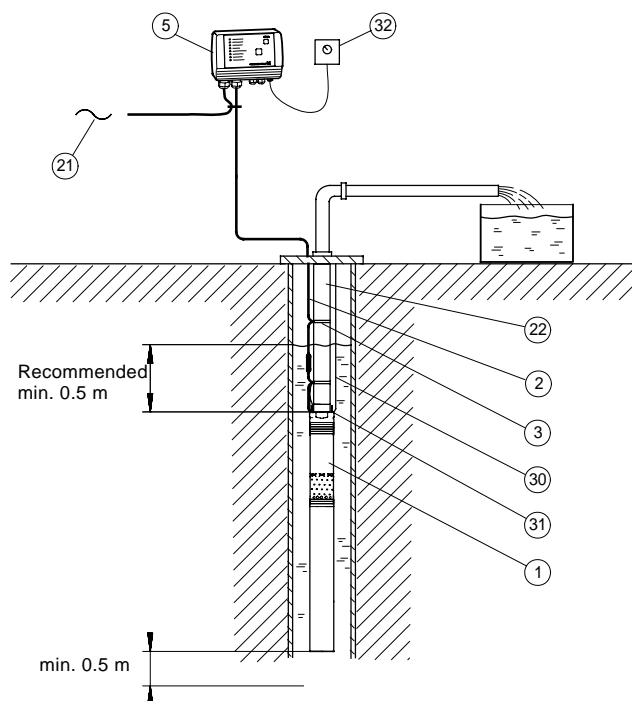

- 1 SQE pump
- 2 Cable
- 3 Cable clips
- 5 Control unit, CU 300
- 21 Mains connection 1 x 220-240 V, 50/60 Hz
- 22 Riser pipe
- 30 Stainless steel straining wire
- 31 Stainless steel wire clamps, 2 per lifting eye
- 32 Potentiometer, SPP1

TM01 9028 4801

## Sampling /manual speed control of SQE

Pos.	Part	Type	No. of units	Product number	Unit price	Total price
1	SQE pump					
2	Cable					
3	Cable clips					
5	Control unit	CU 300				
22	Riser pipe					
30	Stainless steel straining wire					
31	Stainless steel wire clamps	2 per lifting eye				
32	Potentiometer, SPP 1					



## Replacement in existing installation

### Functioning and benefits

SQ can be installed as replacement of a 4" submersible pump in an existing installation.

When water is consumed, water is taken from the pressure tank without the pump being in operation. If the preset cut-in pressure ( $P_{\text{cut-in}}$ ) is reached, the pump starts operating. The pump starts operating in the soft-start mode (run-up time approx. 3 seconds). Within this time the pressure may drop down to minimum pressure ( $P_{\text{min.}}$ ).

When water consumption stops, the pump builds up system pressure until the preset cut-out pressure ( $P_{\text{cut-out}}$ ) of the pressure switch is reached and the pump cut out.

At this time the riser pipe between the aerator with non-return valve and the water table is emptied of water. This water is replaced by an amount of air which is pressed to the pressure tank every time the pump starts operating. The air, which serves as an air cushion, is absorbed by the pressure tank or let out to the atmosphere through the air vent. It should be tested whether the pump chosen can reach  $P_{\text{cut-out}} + A$  (see "Selection of pressure tank" page 30).

The system must be designed for maximum pump pressure.

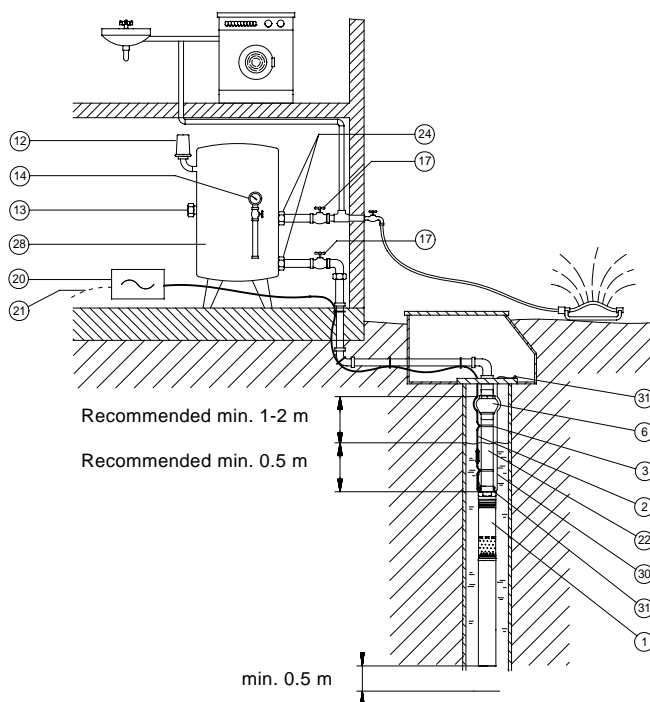

- 1 Pump, SQ
- 2 Cable
- 3 Cable clips
- 6 Aerator with non-return valve
- 12 Pressure switch
- 13 Air vent
- 14 Pressure gauge
- 17 Isolating valve
- 20 Mains switch
- 21 Mains connection, 1 x 200-240 V, 50/60 Hz
- 22 Riser pipe
- 24 Union
- 28 Pressure tank
- 30 Straining wire
- 31 Wire clamp

**Note:** Do not install draw-off points between the pump and the pressure tank.

Pos. 6: If the aerator remains in the installation, the non. return valve in the SQ pump should be removed.

TM01 2988 2898

## Replacement in existing installation

Pos.	Part	Type	No. of units	Product number	Unit price	Total price
1	Pump, SQ					
2	Cable					
3	Cable clips					
6	Aerator with non-return valve					
12	Pressure switch					
13	Air vent					
14	Pressure gauge					
20	Mains switch					
30	Straining wire					
31	Wire clamp					

## CU 301, control unit

The CU 301 is a control and communication unit especially developed for the SQE submersible pumps in constant pressure applications.

The CU 301 control unit provides:

- Full control of the SQE pumps.
- Two-way communication with the SQE pumps.
- Possibility of adjusting the pressure.
- Alarm indication (LED) when service is needed.
- The possibility of starting, stopping and resetting the pump simply by means of a push-button.
- Communication with remote control, R100

The CU 301 communicates with the pump via mains borne signalling (Power Line Communication), meaning that no extra cables are required between the CU 301 and the pump.

The CU 301 features the following indications (see drawing in right column):

1. Flow indicator
2. System pressure setting
3. System ON/OFF
4. Button lock indicator
5. Dry-running indicator
6. Service needed in case of:
  - No contact to pump
  - Overvoltage
  - Undervoltage
  - Speed reduction
  - Overtemperature
  - Overload
  - Sensor defective

The CU 301 incorporates

- external signal input for pressure sensor.
- connection to an operating relay for indication of pump operation.

## R100, remote control

Wireless infrared remote control of the CU 301 is possible by means of the R100.

Using the R100 it is possible to monitor and change the operating parameters, see the R100 menu structure on page 19.

The R100 is a strong tool in case fault finding is required.

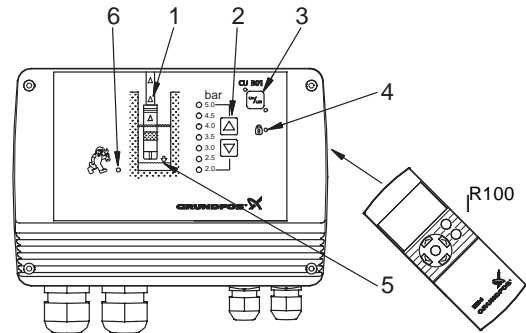

TM03 3426 0406

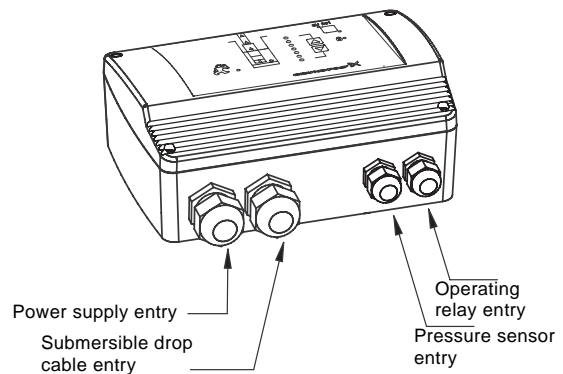

TM02 3427 0406

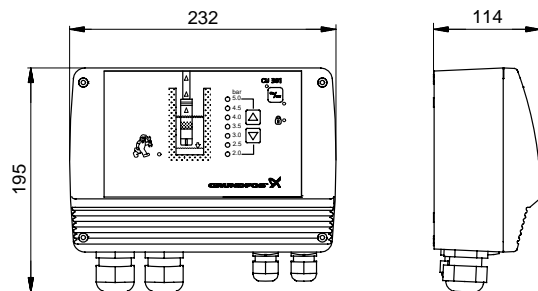

Dimensions stated in mm.

TM03 3003 5005

## R100 menu structure for the CU 301

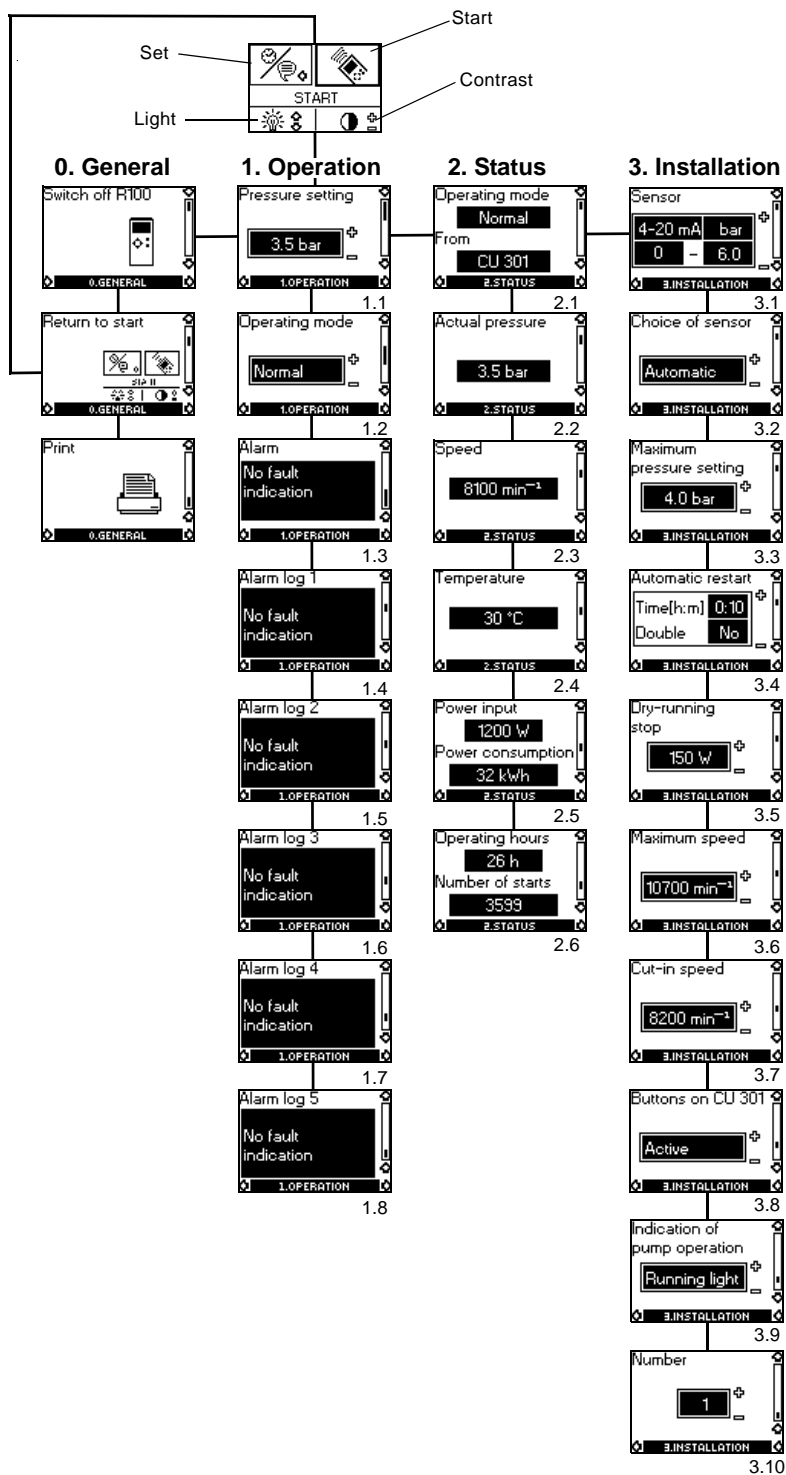

**Note:** This menu is an example, not the factory setting.

## R100 menus for CU 301

### 0. General

### 1. Operation

- 1.1 Setpoint setting.
- 1.2 Selection of operating mode.
- 1.3 Alarm indication.

### 2. Status

The indication of:

- 2.1 Actual operating mode.
- 2.2 Actual pressure.
- 2.3 Actual motor speed.
- 2.4 Actual motor temperature.
- 2.5 Actual power input and accumulated motor power consumption.
- 2.6 Accumulated number of operating hours and accumulated number of starts.

### 3. Installation

- 3.1 Sensor parameters.
- 3.2 Choice of sensor.
- 3.3 Setting of maximum pressure setpoint.
- 3.4 Setting of automatic restart time.
- 3.5 Setting of the dry-running stop limit.
- 3.6 Setting of the maximum motor speed.
- 3.6 Setting of the maximum motor speed.
- 3.7 Setting of the cut-in motor speed.
- 3.8 Activating or deactivating the on/off-button and the buttons for system pressure setting on the CU 301.
- 3.9 Indication of pump operation.
- 3.10 Allocation of number.

### Status report

All settings and measured values can be transferred to a portable printer via wireless infrared communication and be printed in a status report.

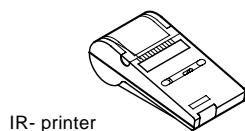

TM00 7982 2293

## CU 300 Control unit

The CU 300 control unit provides:

- Easy adjustment to a specific borehole.
- Full control of the SQE pumps.
- Two-way communication with the SQE pumps.
- Alarm indication of pump operation by diodes on the front, and
- The possibility of starting, stopping and resetting the pump simply by means of a push-button.

The CU 300 communicates with the pump via the power supply cable mains borne signalling or (Power Line Communication), meaning that no extra cables are required between the CU 300 and the pump.

The following alarms can be indicated by the CU 300:

- No contact
- Overvoltage
- Undervoltage
- Dry running
- Speed reduction
- Overtemperature
- Overload
- Sensor alarm

The CU 300 incorporates:

- External signal input for two analog sensors and one digital sensor.
- Relay output for external alarm indication.
- Control according to the signals received, e.g. of flow, pressure, water level and conductivity.

## R100 Remote control

Wireless infrared remote control of the CU 300 is possible by means of the R100.

Using the R100 it is possible to monitor and change the operating parameters, see the R100 menu structure on page 22.

The R100 is a strong tool in case fault finding is required.

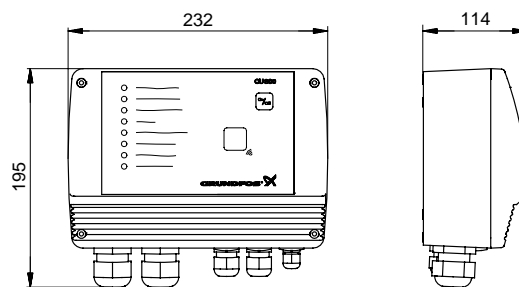
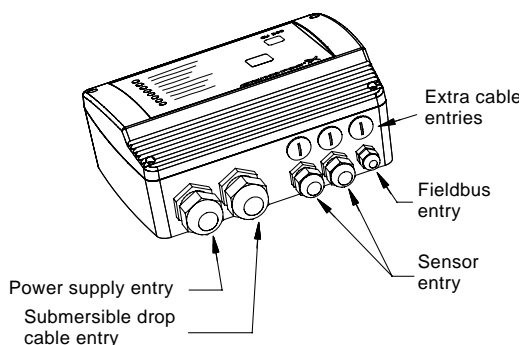
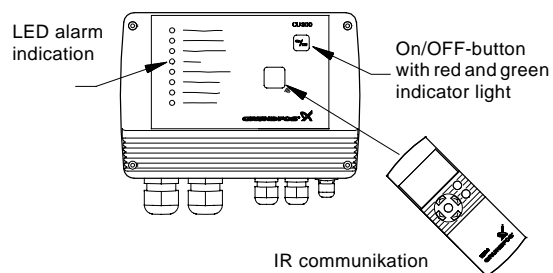

Dimensions stated in mm.

## R100 menu structure for the CU 300

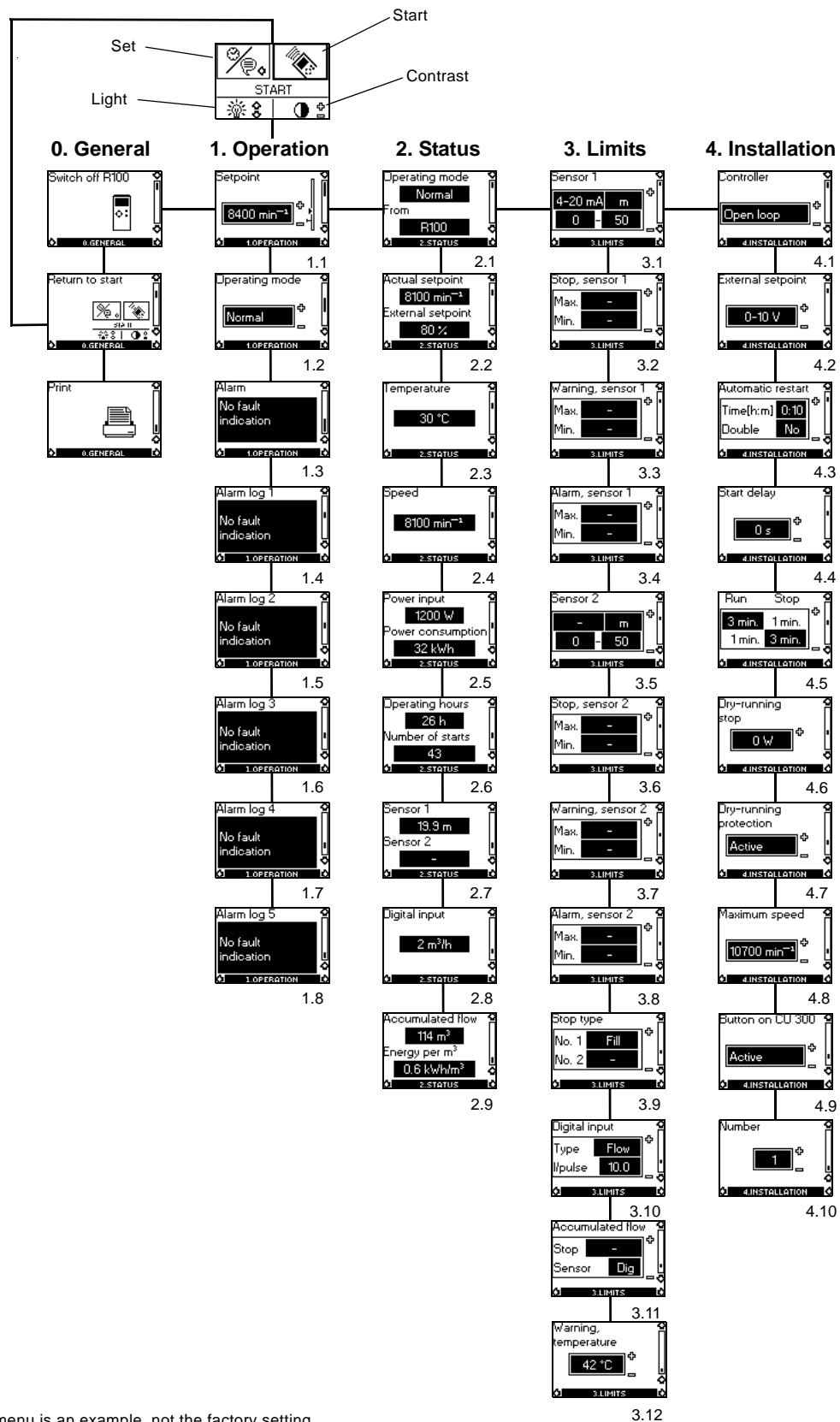

Note: This menu is an example, not the factory setting.

## R100 menus for CU 300

### 0. General

#### 1. Operation

- 1.1 Setpoint setting.
- 1.2 Selection of operating mode.
- 1.3 Alarm indication.

#### 2. Status

The indication of:

- 2.1 Actual operating mode.
- 2.2 Actual and external setpoint.
- 2.3 Actual motor temperature.
- 2.4 Actual motor speed.
- 2.5 Actual power input and accumulated motor power consumption.
- 2.6 Accumulated number of operating hours and accumulated number of starts.
- 2.7 Actual values of sensors 1 and 2, respectively.
- 2.8 Actual values of the digital input.
- 2.9 Accumulated flow, and the power used to pump 1 m<sup>3</sup>.

R100 offers possibility of making a number of settings:

#### 3. Limits

The setting of:

- 3.1 Sensor 1 parameters.
- 3.2 Min. and max. stop limit of sensor 1.
- 3.3 Min. and max. warning limit of sensor 1.
- 3.4 Min. and max. alarm limit of sensor 1.
- 3.5 Sensor 2 parameters.
- 3.6 Min. and max. stop limit of sensor 2.
- 3.7 Min. and max. warning limit of sensor 2.
- 3.8 Min. and max. alarm limit of sensor 2.
- 3.9 Filling or emptying.
- 3.10 Setting of the function of the digital sensor connected to the digital input.
- 3.11 The setting of the water quantity stop limit and the setting of the sensor to detect water quantity.
- 3.12 The setting of the temperature warning limits of the motor electronics.

#### 4. Installation

- 4.1 Selection of controller.
- 4.2 Setting of external setpoint.
- 4.3 Setting of automatic restart time.
- 4.4 Allocation of individual start delays.
- 4.5 Setting of the stop and run times for the dewatering function.
- 4.6 Setting of the dry-running stop limit.
- 4.7 Activating or deactivating the dry-running protection.
- 4.8 Setting of the maximum motor speed.
- 4.9 Activating or deactivating the on/off-button on the CU 300.
- 4.10 Allocation of number where more than one CU 300 is installed.

#### Status report

All settings and measured values can be transferred to a portable printer via wireless infrared communication and be printed in a status report.

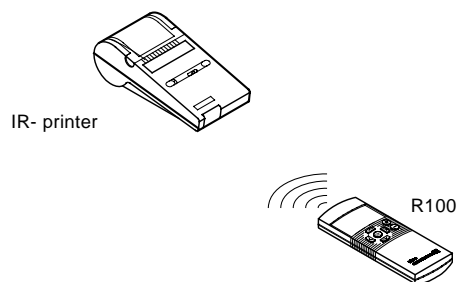

TM00 7982 2293

## Examples of R100 displays

### Menu OPERATION

#### Setpoint setting

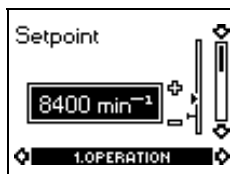

1.1

From factory, the pump is set to maximum speed, 10,700 rpm. R100 makes it possible to reduce the pump speed by changing the setpoint. The speed can be set to 3000 - 10,700 rpm, at 100 rpm intervals.

The unit of the setpoint is automatically changed according to the unit of the sensor connected to sensor input no. 1.

**Example:** Sensor input no. 1 is connected to a pressure sensor using the unit metre (m) and the range 0 - 60. Consequently, the setpoint of display 1.1 can be set to between 0 - 60 m.

### Menu STATUS

The displays appearing in this menu are status displays only. It is not possible to change settings in this menu.

#### Accumulated flow

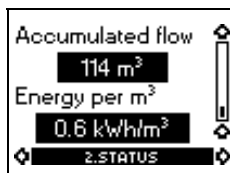

2.9

In display 2.9 the water quantity (m<sup>3</sup>) pumped is shown. The value shown is the accumulated flow registered by the sensor selected in display 3.11.

The power used to pump 1 m<sup>3</sup> is shown in the display as energy per m<sup>3</sup> (kWh/m<sup>3</sup>).

It is possible to read the status of the accumulated flow and energy per m<sup>3</sup> at any time.

#### Accumulated number of operating hours and number of starts

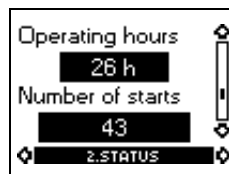

2.6

The value of operating hours and the number of starts are values accumulated from the time of installation and they cannot be reset.

Both values are stored in the motor electronics, and they are kept even if the CU 300 is replaced.

The number of operating hours is registered every two minutes of continuous operation.

### Menu LIMITS

#### Sensor 1

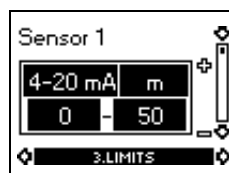

3.1

The setting of sensor 1.

Depending on the type of sensor, the following settings can be made:

- Sensor outputs:
  - (not active), 0-10 V, 2-10 V, 0-20 mA, 4-20 mA.
- Setting range unit: m<sup>3</sup>/h, m, %, GPM, ft.
- Sensor minimum value: 0 - 249 (0,1,2,3.....249)
- Sensor maximum value: 1 - 250 (1,2,3,4.....250)



## Alarm indication

The CU 300 offers the following alarm indications

Alarm	Description	The pump will be restarted automatically
<b>No contact</b>	No contact/communication between the CU 300 and the SQE pump. <b>Note:</b> This Alarm does not influence pump operation.	–
<b>Overvoltage</b>	The supply voltage exceeds the voltage range.	when voltage is within specified range.
<b>Undervoltage</b>	The supply voltage is below the voltage range.	when voltage is within specified range.
<b>Dry running</b>	The dry-running protection of the pump has been activated.	after 5 min. (default), or a period set via R100.
<b>Speed reduction</b>	The motor speed is reduced. <b>Note:</b> Speed resuming when cause has been remedied or has disappeared.	–
<b>Overtemperature</b>	The motor temperature exceeds the temperature limit.	when motor electronics have cooled down sufficiently.
<b>Overload</b>	The current consumption of the motor exceeds the value set.	after 5 min. (default), or a period set via R100.
<b>Sensor alarm</b>	Sensor alarm may be caused by: <ul style="list-style-type: none"> <li>• The measured value has fallen outside the measuring range set.</li> <li>• The sensor is defective.</li> <li>• The sensor output setting made via R100 is incorrect.</li> </ul>	after 5 min. (default), or a period set via R100.

## Benefits of CU 300/R100

Alarm	Description	The following are no longer required
<b>No contact</b>	Provides knowledge of contact between the SQE pump and the CU 300.	–
<b>Overvoltage</b>	The supply voltage is measured.	Overvoltage relay.
<b>Undervoltage</b>	The supply voltage is measured.	Undervoltage relay.
<b>Dry running</b>	Provides dry-running protection of the pump.	Level relay, electrodes, cables.
<b>Speed reduction</b>	Ensures pump operation at a moderate undervoltage and overload, thereby ensuring that the motor is not overloaded.	Urgent need for service.
<b>Overtemperature</b>	The pump is stopped at a too high temperature. When the motor electronics have cooled down sufficiently, the motor will restart automatically.	–
<b>Overload</b>	Provides overload protection of the motor.	Motor starter.
<b>Sensor alarm</b>	Sensors can be connected directly to the CU 300. The sensor signals are monitored.	External control unit.

## Determining head and flow

Pump selection is based on the water demand and the required head.

### 1. Water demand

The manufacturers of fittings and sprinkler systems normally state this data.

Examples of water demand:

Sprinkler systems:	1.5 m <sup>3</sup> /h per sprinkler
Domestic water supply:	2-4 m <sup>3</sup> /h
Agriculture:	4-6 m <sup>3</sup> /h
Irrigation:	6-8 m <sup>3</sup> /h

### 2. Head

$$H[m] = p_{tap} \times 10.2 + H_{geo} + H_f$$

$p_{tap}$  = Required pressure at the draw-off point (e.g. sprinkler), at least 2 bar.

$H_{geo}$  = Difference of height between lower water level in well and draw-off point.

$H_f$  = Loss of head in piping and tubing.

Note table below.

### Head losses ( $H_f$ ) in plastic pipes and ordinary water pipes:

Upper figures indicate the velocity of water in m/sec.

metres of straight pipes.

Lower figures indicate head loss in metres per 100

Quantity of water			Plastic pipes*(PELM/PEH PN 10 PELM)				Ordinary water pipes**				
m <sup>3</sup> /h	Litres/min.	Litres/sec.	Nominal pipe diameter in inches and internal diameter in [mm]								
			25 20.4	32 26.2	40 32.6	50 40.8	1/2" 15.75	3/4" 21.25	1" 27.00	1 1/4" 35.75	1 1/2" 41.25
0.6	10	0.16	0.49 1.8	0.30 0.66	0.19 0.27	0.12 0.085	0.855 9.910	0.470 2.407	0.292 0.784		
0.9	15	0.25	0.76 4.0	0.46 1.14	0.3 0.6	0.19 0.18	1.282 20.11	0.705 4.862	0.438 1.570	0.249 0.416	
1.2	20	0.33	1.0 6.4	0.61 2.2	0.39 0.9	0.25 0.28	1.710 33.53	0.940 8.035	0.584 2.588	0.331 0.677	0.249 0.346
1.5	25	0.42	1.3 10.0	0.78 3.5	0.5 1.4	0.32 0.43	2.138 49.93	1.174 11.91	0.730 3.834	0.415 1.004	0.312 0.510
1.8	30	0.50	1.53 13.0	0.93 4.6	0.6 1.9	0.38 0.57	2.565 69.34	1.409 16.50	0.876 5.277	0.498 1.379	0.374 0.700
2.1	35	0.58	1.77 16.0	1.08 6.0	0.69 2.0	0.44 0.70	2.993 91.54	1.644 21.75	1.022 6.949	0.581 1.811	0.436 0.914
2.4	40	0.67	2.05 22.0	1.24 7.5	0.80 3.3	0.51 0.93		1.879 27.66	1.168 8.820	0.664 2.290	0.499 1.160
3.0	50	0.83	2.54 37.0	1.54 11.0	0.99 4.8	0.63 1.40		2.349 41.40	1.460 13.14	0.830 3.403	0.623 1.719
3.6	60	1.00	3.06 43.0	1.85 15.0	1.2 6.5	0.76 1.90		2.819 57.74	1.751 18.28	0.996 4.718	0.748 2.375
4.2	70	1.12	3.43 50.0	2.08 18.0	1.34 8.0	0.86 2.50		3.288 76.49	2.043 24.18	1.162 6.231	0.873 3.132
4.8	80	1.33		2.47 25.0	1.59 10.5	1.02 3.00			2.335 30.87	1.328 7.940	0.997 3.988
5.4	90	1.50		2.78 30.0	1.8 12.0	1.15 3.50			2.627 38.30	1.494 9.828	1.122 4.927
6.0	100	1.67		3.1 39.0	2.0 16.0	1.28 4.6			2.919 46.49	1.660 11.90	1.247 5.972
7.5	125	2.08		3.86 50.0	2.49 24.0	1.59 6.6			3.649 70.41	2.075 17.93	1.558 8.967
9.0	150	2.50			3.00 33.0	1.91 8.6				2.490 25.11	1.870 12.53
10.5	175	2.92			3.5 38.0	2.23 11.0				2.904 33.32	2.182 16.66
90° bends, slide valves							1.0	1.0	1.1	1.2	1.3
T-pieces, non-return valves							4.0	4.0	4.0	5.0	5.0

\* The table is based on a nomogram.  
Roughness: K = 0.01 mm.  
Water temperature: t = 10°C.

\*\* The data are calculated in accordance with H. Lang's new formula a = 0.02 and for a water temperature of 10°C.  
The head loss in bends, slide valves, T-pieces and non-return valves is equivalent to the metres of straight pipes stated in the last two lines of the table.

### Example of calculation: Domestic water supply.

Required flow: 2.4 m<sup>3</sup>/h

$$p_{tap} = 3 \text{ bar}$$

$$H_{geo} = 30 \text{ m}$$

$$H_f = 7.7 \text{ m}$$

The tubing is made of plastic pipe,  $\varnothing 25$ , length 35 m.

This will give:

$$H_f = \text{Value from table} \times \text{length of pipe}$$

$$H_f = 0.22 \times 35 \text{ m} = 7.7 \text{ m}$$

$$H[m] = p_{tap} \times 10.2 + H_{geo} + H_f$$

$$= 3 \times 10.2 + 30 \text{ m} + 7.7 = 68.3 \text{ m}$$

Selected at Q = 2.4 m<sup>3</sup>/h, H = 68.3 m

For selection of the pump type best meeting the requirements, see the next page.

## Pump sizing

**Important:** The dry-running protection is effective only within the recommended pump duty range, i.e. the bold curves. See performance curves.

Pump type	Power, pump [kW]	Flow rate Q [m <sup>3</sup> /h] / [l/s]													Max. head [m] (Q= 0 m <sup>3</sup> /h)	Full-load current I <sub>1/1</sub> [A]		Pipe connection Rp
		0.5/ 0.14	1.0/ 0.28	1.5/ 0.42	2.0/ 0.56	2.5/ 0.70	3.0/ 0.83	3.5/ 0.97	4.0/ 1.11	5.0/ 1.39	6.0/ 1.67	7.0/ 1.95	8.0/ 2.22	9.0/ 2.50		230V	200V	
		Head [m]																
SQ 1 - 35	0.29	43	34	20	-	-	-	-	-	-	-	-	-	-	47	2.1	2.4	1¼
SQ 1 - 50	0.44	65	52	32	-	-	-	-	-	-	-	-	-	-	71	2.9	3.4	1¼
SQ 1 - 65	0.58	88	70	44	-	-	-	-	-	-	-	-	-	-	94	3.7	4.4	1¼
SQ 1 - 80	0.73	110	89	56	-	-	-	-	-	-	-	-	-	-	118	4.6	5.3	1¼
SQ 1 - 95	0.87	132	107	68	-	-	-	-	-	-	-	-	-	-	142	5.3	6.2	1¼
SQ 1 - 110	1.03	155	125	80	-	-	-	-	-	-	-	-	-	-	166	6.2	7.3	1¼
SQ 1 - 125	1.20	177	144	93	-	-	-	-	-	-	-	-	-	-	189	7.2	8.6	1¼
SQ 1 - 140	1.37	199	162	104	-	-	-	-	-	-	-	-	-	-	213	8.1	9.7	1¼
SQ 1 - 155	1.55	222	180	117	-	-	-	-	-	-	-	-	-	-	237	9.2	10.5	1¼
SQ 2 - 35	0.45	43	42	39	35	29	19	-	-	-	-	-	-	-	45	2.9	3.5	1¼
SQ 2 - 55	0.65	66	63	60	54	45	32	-	-	-	-	-	-	-	68	4.1	4.9	1¼
SQ 2 - 70	0.87	87	84	79	72	60	43	-	-	-	-	-	-	-	89	5.3	6.2	1¼
SQ 2 - 85	0.98	108	105	99	89	74	54	-	-	-	-	-	-	-	109	6.0	6.9	1¼
SQ 2 - 100	1.30	131	128	120	109	91	67	-	-	-	-	-	-	-	132	7.7	9.3	1¼
SQ 2 - 115	1.50	154	150	142	129	108	79	-	-	-	-	-	-	-	155	8.9	10.2	1¼
SQ 3 - 30	0.44	-	-	34	32	30	26	22	-	-	-	-	-	-	36	2.9	3.4	1¼
SQ 3 - 40	0.63	-	-	53	50	47	42	36	-	-	-	-	-	-	56	4.0	4.8	1¼
SQ 3 - 55	0.83	-	-	70	67	63	56	48	-	-	-	-	-	-	74	5.1	5.9	1¼
<b>SQ 3 - 65</b>	<b>1.02</b>	-	-	87	83	<b>78</b>	70	60	-	-	-	-	-	-	92	<b>6.2</b>	<b>7.2</b>	<b>1¼</b>
SQ 3 - 80	1.23	-	-	105	100	94	85	73	-	-	-	-	-	-	110	7.4	8.8	1¼
SQ 3 - 95	1.43	-	-	123	117	109	99	85	-	-	-	-	-	-	129	8.4	10.1	1¼
SQ 3 - 105	1.63	-	-	140	134	125	113	97	-	-	-	-	-	-	147	9.7	11.0	1¼
SQ 5 - 15	0.26	-	-	-	-	-	15	14	13	11	7	-	-	-	18	1.9	2.2	1½
SQ 5 - 25	0.54	-	-	-	-	-	31	29	28	24	18	-	-	-	36	3.4	4.1	1½
SQ 5 - 35	0.80	-	-	-	-	-	46	44	42	36	28	-	-	-	54	4.9	5.7	1½
SQ 5 - 50	1.06	-	-	-	-	-	62	59	56	49	38	-	-	-	71	6.5	7.7	1½
SQ 5 - 60	1.33	-	-	-	-	-	77	74	70	61	48	-	-	-	89	7.9	9.4	1½
SQ 5 - 70	1.60	-	-	-	-	-	93	89	85	73	58	-	-	-	106	9.5	10.8	1½
SQ 7 - 15	0.42	-	-	-	-	-	-	17	16	14	12	9	6	2	21	2.8	3.3	1½
SQ 7 - 30	0.84	-	-	-	-	-	-	36	35	32	29	24	18	10	42	5.2	6.0	1½
SQ 7 - 40	1.27	-	-	-	-	-	-	56	54	50	45	38	29	19	64	7.6	9.1	1½

### Example:

Required: Flow rate: 2.4 m<sup>3</sup>/h => nearest higher value in table is 2.5 m<sup>3</sup>/h.

Head: 68.3 m => nearest higher value in the table is 78 m.

Selected: Pump type: SQ 3-65 (as it offers the best pump efficiency for the required flow and head).

Required pump power input: 1.02 kW.

Full load current: I<sub>1/1</sub> = 6.2 A at 230 V.

I<sub>1/1</sub> = 7.2 A at 200 V.

Pipe connection: Rp 1¼.

Length of pump: 826 mm

## Example:

### How to select an SQ pump

- A head of 68 m and a flow of 2.4 m<sup>3</sup>/h is required.
- The pump type best meeting these requirements is SQ 3. In the curve chart below, draw a rightward, horizontal line from the head required 68 m (1) to the intersection with the vertical line from the required flow (2). In this example the intersection point (3) of the two lines is not on one of the pump curves, therefore follow the pipe characteristic upwards. The intersection point of the pump curve and the pipe characteristic (4) gives the size of the pump. The size of the pump is: SQ 3 - 65.
- The pump power input per stage (P<sub>2</sub>) can be read to be 0.20 kW (5), and the pump efficiency per stage is 57% (6).
- SQ 3 - 65 has 5 stages, see page 36. With 5 stages the total pump power input for SQ 3 - 65 is 1.02 kW, (0.20 kW x 5) which means an MS 3 1.15 kW motor.

### How to select an SQE pump

The procedure for selecting an SQE pump is identical to the procedure for selecting an SQ pump.

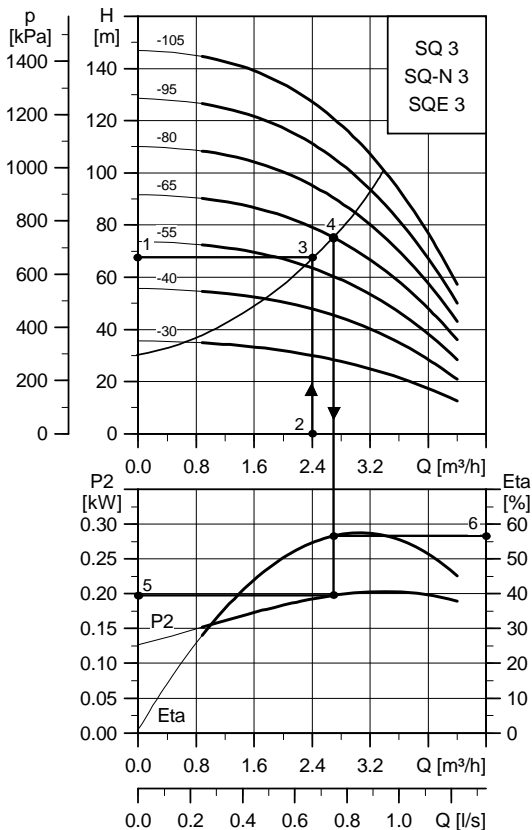

TM01 3046 4801

## Variable speed

The performance of the SQE pump can be adjusted to a specific duty point within its performance range. This is done by means of CU 300 or CU 301 and R100. The SQE pump is ideal especially in cases when the water consumption varies over time and when the duty point is between two pump curves as energy savings can be achieved by reducing the performance to the required speed. The curve chart below shows the performance of an SQE 5-70 pump at various speeds.

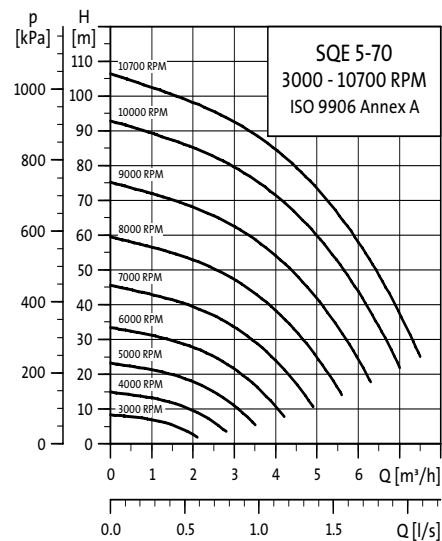

TM01 3220 4304

## Curve conditions

The guidelines below apply to the performance curves on pages page 32 to page 41:

### General

- Tolerances according to ISO 9906, Annex A, i.e. all curves show mean values.
- None of the curves must be used as guarantee curves.
- The **bold** curves show the **recommended** duty range.
- The measurements were made with airless water at a temperature of 20°C.
- The conversion between head H (m) and pressure p (kPa) applies to water with a density of 1,000 kg/m<sup>3</sup>.
- The curves apply to a kinematic viscosity of 1 mm<sup>2</sup>/s (1 cSt). If the pump is used for liquids with a viscosity higher than that of water, this will reduce the head and increase the power consumption.
- **Q/H:** The curves are inclusive of valve and inlet losses at the actual speed.
- **Power curve:** P<sub>2</sub> shows pump power input per stage.
- **Efficiency curve:** Eta shows pump efficiency per stage.

## Selecting the right pump for the SQE constant-pressure system

Dynamic head [m]	Nom. flow [m <sup>3</sup> /h]	System pressure [bar]						
		2.0	2.5	3.0	3.5 (C)	4.0	4.5	5.0
10 to 20	2	← SQE 2-55 →		← SQE 2-85 →				
	2	← SQE 3-65 →			← SQE 2-85 →			
	3	← SQE 5-50 →		← SQE 3-65 →				
	5	← SQE 5-70 →			← SQE 5-70 →			
	5	← SQE 2-55 →		← SQE 5-70 →				
21 to 30 (A)	2	← SQE 2-55 →		← SQE 2-85 →				
	2	← SQE 3-65 →			← SQE 2-85 →			
	3 (B)	← SQE 5-70 →		← SQE 3-105 →				
	5	← SQE 5-70 →			← SQE 3-105 →			
31 to 40	2	← SQE 2-85 →		← SQE 2-115 →				
	2	← SQE 3-65 →			← SQE 2-115 →			
	3	← SQE 3-105 →		← SQE 3-105 →				
	3	← SQE 5-70 →			← SQE 3-105 →			
41 to 50	2	← SQE 2-85 →		← SQE 2-115 →				
	3	← SQE 3-105 →			← SQE 2-115 →			
51 to 60	2	← SQE 3-105 →		← SQE 2-115 →				
	3	← SQE 3-105 →			← SQE 2-115 →			
61 to 70	2	← SQE 3-105 →		← SQE 2-115 →				
	3	← SQE 3-105 →			← SQE 2-115 →			
71 to 80	2	← SQE 2-115 →		← SQE 2-115 →				
81 to 90	2	← SQE 2-115 →			← SQE 2-115 →			

### Example: How to select an SQE pump

#### Required:

Total head (from water level to water tap, including friction loss):

25 m (A)

Maximum flow rate: 3 m<sup>3</sup>/h (B)

System pressure: 3.5 bar (C)

#### Selected:

Pump type: SQE 3-65.

The system pressure can be adjusted to any constant pressure from 2 to 4 bar (D).

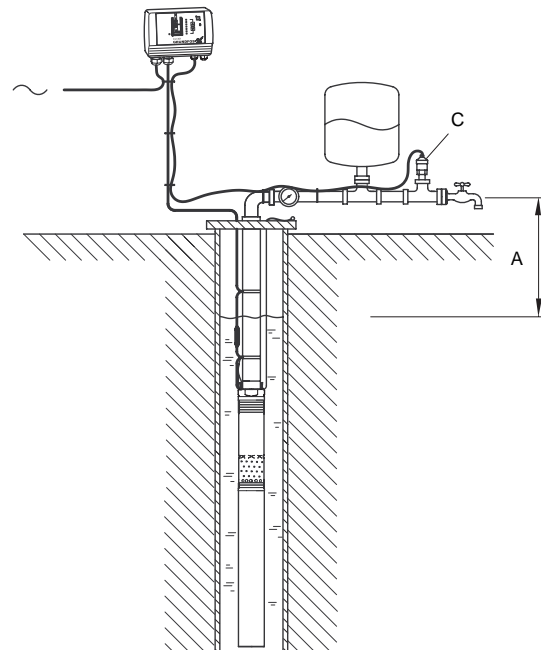

TM03 3431 0406

## Selection of pressure tank

The electronic unit in SQ ensures a smooth start-up. To yield sufficient pressurized water in the period when the pump is not in operation a pressure tank can be fitted in the water supply system.

During start-up the system pressure will fall below the cut-in pressure of the pressure switch. This value called  $p_{min}$  is to be determined before sizing the pressure tank.

$p_{min}$  is the required minimum pressure at the highest tap point + head and valve and friction loss from the pressure tank to the highest tap point (C + B).

Furthermore, the flow at  $p_{min}$  has to be determined. This is called  $Q_{max}$  and is found in the performance curve for the pump type in question.

Use  $p_{min}$  and  $Q_{max}$  in the table below to find the size of the pressure tank, the precharge pressure of the pressure tank and the cut-in and cut-out pressure setting of the pressure switch.

**Note:** If a minimum pressure is not required, an 18 l pressure tank is sufficient for all SQ pumps.

- $p_{pre}$ : Precharge pressure of the pressure tank.
- $p_{min}$ : Required min. pressure.
- $p_{cut-in}$ : Cut-in pressure of the pressure switch.
- $p_{cut-out}$ : Cut-out pressure of the pressure switch.
- $Q_{max}$ : The flow at  $p_{min}$ .

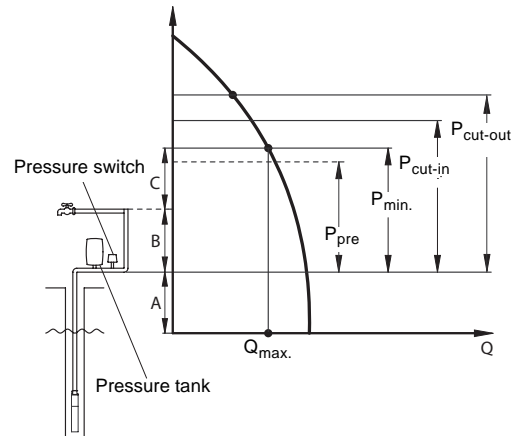

TM00 6445 3795

- A: Head + pipe friction from dynamic water level to pressure tank.
- B: Head + pipe friction from pressure tank to the top tap point.
- C: Min. pressure at the highest point.

**Note:** Be sure that the selected pump can deliver a pressure higher than  $p_{cut-out} + A$ .

$p_{min}$ [m]	$Q_{max}$ [m <sup>3</sup> /h]																$p_{pre}$ [m]	$p_{cut-in}$ [m]	$p_{cut-out}$ [m]		
	0.6	0.8	1	1.2	1.5	2	2.5	3	3.5	4	4.5	5	5.5	6	6.5	7				7.5	8
	Pressure tank size [litres]																				
25	8	8	18	18	18	18	24	33	33	50	50	50	50	80	80	80	80	80	22.5	26	40
30	8	8	18	18	18	24	33	33	50	50	50	50	80	80	80	80	80	80	27	31	45
35	8	18	18	18	18	24	33	33	50	50	50	80	80	80	80	80			31.5	36	50
40	8	18	18	18	18	24	33	50	50	50	80	80	80	80	80				36	41	55
<b>45</b>	8	18	18	18	24	33	<b>33</b>	50	50	50	80	80	80	80					<b>40.5</b>	<b>46</b>	<b>60</b>
50	8	18	18	18	24	33	50	50	50	80	80	80	80						45	51	65
55	18	18	18	18	24	33	50	50	50	80	80	80							49.5	56	70
60	18	18	18	18	24	33	50	50	80	80	80	80							54	61	75
65	18	18	18	24	24	33	50	50	80	80	80	80							58.5	66	80

**Note:** The pressure tank sizes stated in the table are minimum requirements.

The use of a tank one size bigger is recommended.

1 m head = 0.098 bar

### Example:

$p_{min}$ : 45 m,  $Q_{max}$  = 2.5 m<sup>3</sup>/h

The following values are found in the table:

Minimum size of pressure tank = 33 litres.

- $p_{pre}$  = 40.5 m
- $p_{cut-in}$  = 46 m
- $p_{cut-out}$  = 60 m



## SQ 1, SQ 1-N, SQE 1, SQE 1-N

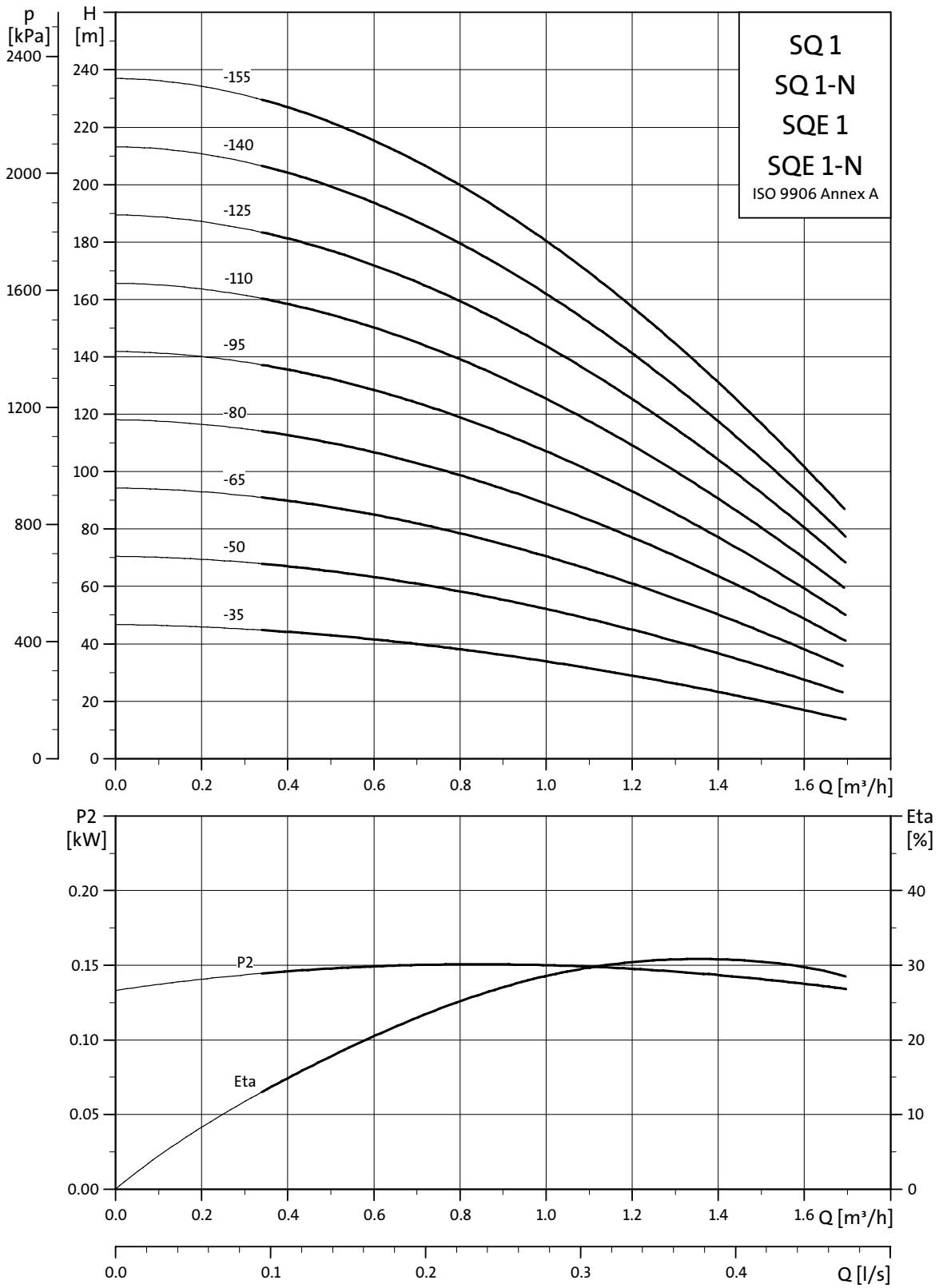

TM01 2692 4304



## Dimensions and weights

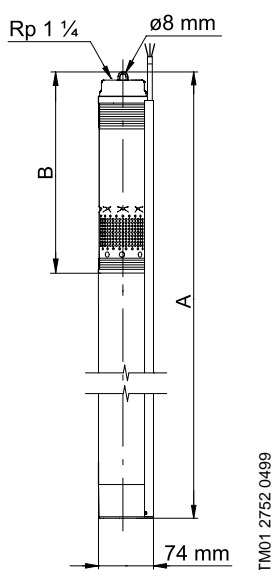

Pump type	Number of stages	Motor		Dimensions [mm]		Net weight [kg]*	Shipping volume [m <sup>3</sup> ]*
		Type	Output power (P <sub>2</sub> ) [kW]	A	B		
SQ 1 - 35 (-N)	2	MS 3 (-NE)	0.70	741	265	4.7	0.0092
SQE 1 - 35 (-N)		MSE 3 (-NE)					
SQ 1 - 50 (-N)	3	MS 3 (-NE)	0.70	741	265	4.8	0.0092
SQE 1 - 50 (-N)		MSE 3 (-NE)					
SQ 1 - 65 (-N)	4	MS 3 (-NE)	0.70	768	292	4.9	0.0094
SQE 1 - 65 (-N)		MSE 3 (-NE)					
SQ 1 - 80 (-N)	5	MS 3 (-NE)	1.15	825	346	5.6	0.0100
SQE 1 - 80 (-N)		MSE 3 (-NE)					
SQ 1 - 95 (-N)	6	MS 3 (-NE)	1.15	825	346	5.6	0.0100
SQE 1 - 95 (-N)		MSE 3 (-NE)					
SQ 1 - 110 (-N)	7	MS 3 (-NE)	1.15	852	373	5.7	0.0103
SQE 1 - 110 (-N)		MSE 3 (-NE)					
SQ 1 - 125 (-N)	8	MS 3 (-NE)	1.68	942	427	6.4	0.0113
SQE 1 - 125 (-N)		MSE 3 (-NE)					
SQ 1 - 140 (-N)	9	MS 3 (-NE)	1.68	942	427	6.5	0.0113
SQE 1 - 140 (-N)		MSE 3 (-NE)					
SQ 1 - 155 (-N)	10	MS 3 (-NE)	1.85	969	454	6.7	0.0116
SQE 1 - 155 (-N)		MSE 3 (-NE)					

\* Including pump, motor, 1.5 m cable and cable guard.

## Electrical data

1 x 200 - 240 V, 50/60 Hz

Pump type	Motor type	Input power, motor (P <sub>1</sub> ) [kW]	Output power motor (P <sub>2</sub> ) [kW]	Required input power, pump [kW]	Full load current I <sub>1/1</sub> [A]		Full load motor efficiency (η) [%]
					230 V	200 V	
SQ 1 - 35 (-N)	MS 3 (-NE)	0.48	0.70	0.29	2.1	2.4	70
SQE 1 - 35 (-N)	MSE 3 (-NE)						
SQ 1 - 50 (-N)	MS 3 (-NE)	0.67	0.70	0.44	2.9	3.4	70
SQE 1 - 50 (-N)	MSE 3 (-NE)						
SQ 1 - 65 (-N)	MS 3 (-NE)	0.86	0.70	0.58	3.7	4.4	70
SQE 1 - 65 (-N)	MSE 3 (-NE)						
SQ 1 - 80 (-N)	MS 3 (-NE)	1.05	1.15	0.73	4.6	5.3	73
SQE 1 - 80 (-N)	MSE 3 (-NE)						
SQ 1 - 95 (-N)	MS 3 (-NE)	1.22	1.15	0.87	5.3	6.2	73
SQE 1 - 95 (-N)	MSE 3 (-NE)						
SQ 1 - 110 (-N)	MS 3 (-NE)	1.43	1.15	1.03	6.2	7.3	73
SQE 1 - 110 (-N)	MSE 3 (-NE)						
SQ 1 - 125 (-N)	MS 3 (-NE)	1.68	1.68	1.20	7.2	8.6	74
SQE 1 - 125 (-N)	MSE 3 (-NE)						
SQ 1 - 140 (-N)	MS 3 (-NE)	1.89	1.68	1.37	8.1	9.7	74
SQE 1 - 140 (-N)	MSE 3 (-NE)						
SQ 1 - 155 (-N)	MS 3 (-NE)	2.09	1.85	1.55	9.2	10.5	74
SQE 1 - 155 (-N)	MSE 3 (-NE)						

## SQ 2, SQ 2-N, SQE 2, SQE 2-N

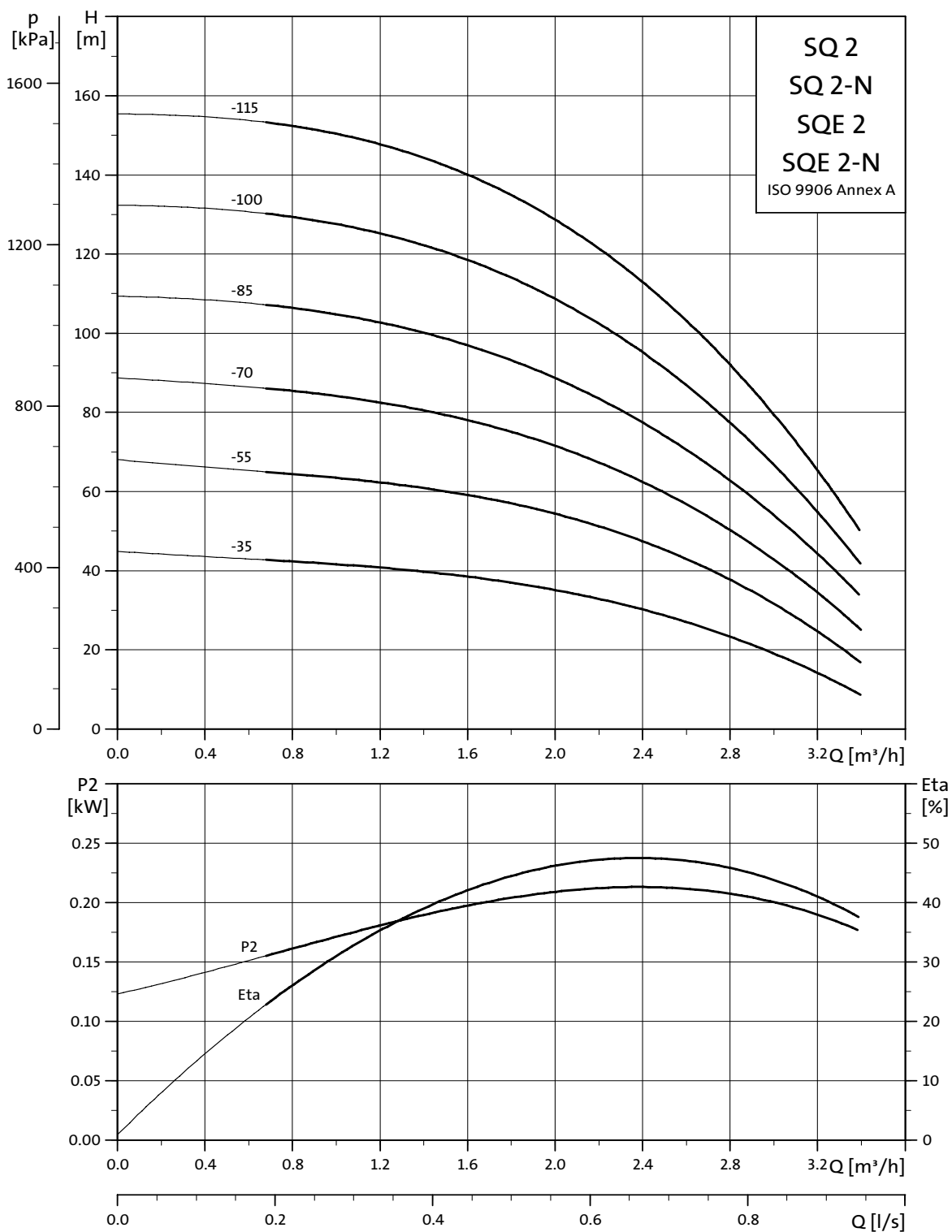

TM01 2693 4304

## Dimensions and weights

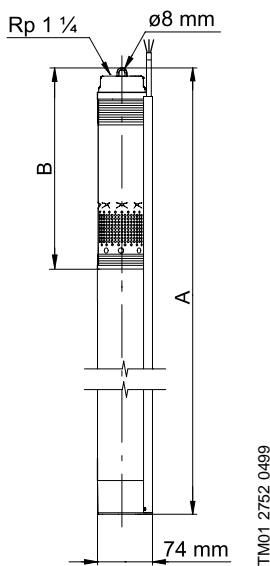

Pump type	Number of stages	Motor Type	Motor Output power (P <sub>2</sub> ) [kW]	Dimensions [mm]		Net weight [kg]*	Shipping volume [m <sup>3</sup> ]*
				A	B		
SQ 2 - 35 (-N)	2	MS 3 (-NE)	0.70	741	265	4.7	0.0092
SQE 2 - 35 (-N)		MSE 3 (-NE)					
SQ 2 - 55 (-N)	3	MS 3 (-NE)	0.70	741	265	5.2	0.0092
SQE 2 - 55 (-N)		MSE 3 (-NE)					
SQ 2 - 70 (-N)	4	MS 3 (-NE)	1.15	768	292	5.4	0.0094
SQE 2 - 70 (-N)		MSE 3 (-NE)					
SQ 2 - 85 (-N)	5	MS 3 (-NE)	1.15	825	346	6.2	0.0104
SQE 2 - 85 (-N)		MSE 3 (-NE)					
SQ 2 - 100 (-N)	6	MS 3 (-NE)	1.68	861	346	6.2	0.0104
SQE 2 - 100 (-N)		MSE 3 (-NE)					
SQ 2 - 115 (-N)	7	MS 3 (-NE)	1.85	888	373	6.3	0.0107
SQE 2 - 115 (-N)		MSE 3 (-NE)					

\* Including pump, motor, 1.5 m cable and cable guard.

## Electrical data

1 x 200 - 240 V, 50/60 Hz

Pump type	Motor type	Input power, motor (P <sub>1</sub> ) [kW]	Output power motor (P <sub>2</sub> ) [kW]	Required input power, pump [kW]	Full load current I <sub>1/1</sub> [A]		Full load motor efficiency (η) [%]
					230 V	200 V	
SQ 2 - 35 (-N)	MS 3 (-NE)	0.69	0.70	0.45	2.9	3.5	70
SQE 2 - 35 (-N)	MSE 3 (-NE)						
SQ 2 - 55 (-N)	MS 3 (-NE)	0.95	0.70	0.65	4.1	4.9	70
SQE 2 - 55 (-N)	MSE 3 (-NE)						
SQ 2 - 70 (-N)	MS 3 (-NE)	1.22	1.15	0.87	5.3	6.2	73
SQE 2 - 70 (-N)	MSE 3 (-NE)						
SQ 2 - 85 (-N)	MS 3 (-NE)	1.36	1.15	0.98	6.0	6.9	73
SQE 2 - 85 (-N)	MSE 3 (-NE)						
SQ 2 - 100 (-N)	MS 3 (-NE)	1.80	1.68	1.30	7.7	9.3	74
SQE 2 - 100 (-N)	MSE 3 (-NE)						
SQ 2 - 115 (-N)	MS 3 (-NE)	2.02	1.85	1.50	8.9	10.2	74
SQE 2 - 115 (-N)	MSE 3 (-NE)						

## SQ 3, SQ 3-N, SQE 3, SQE 3-N

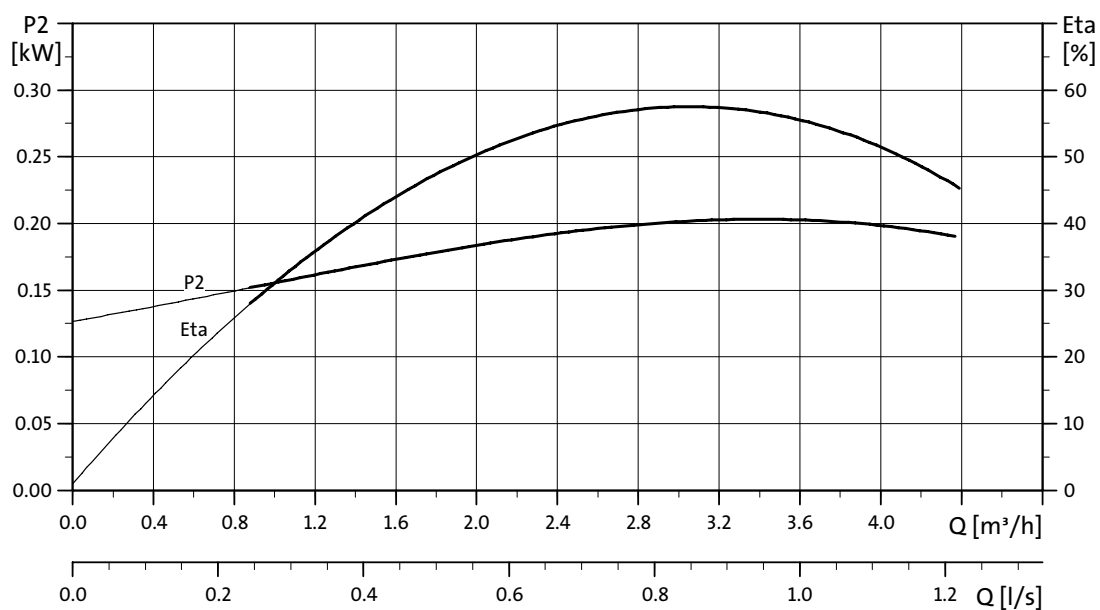
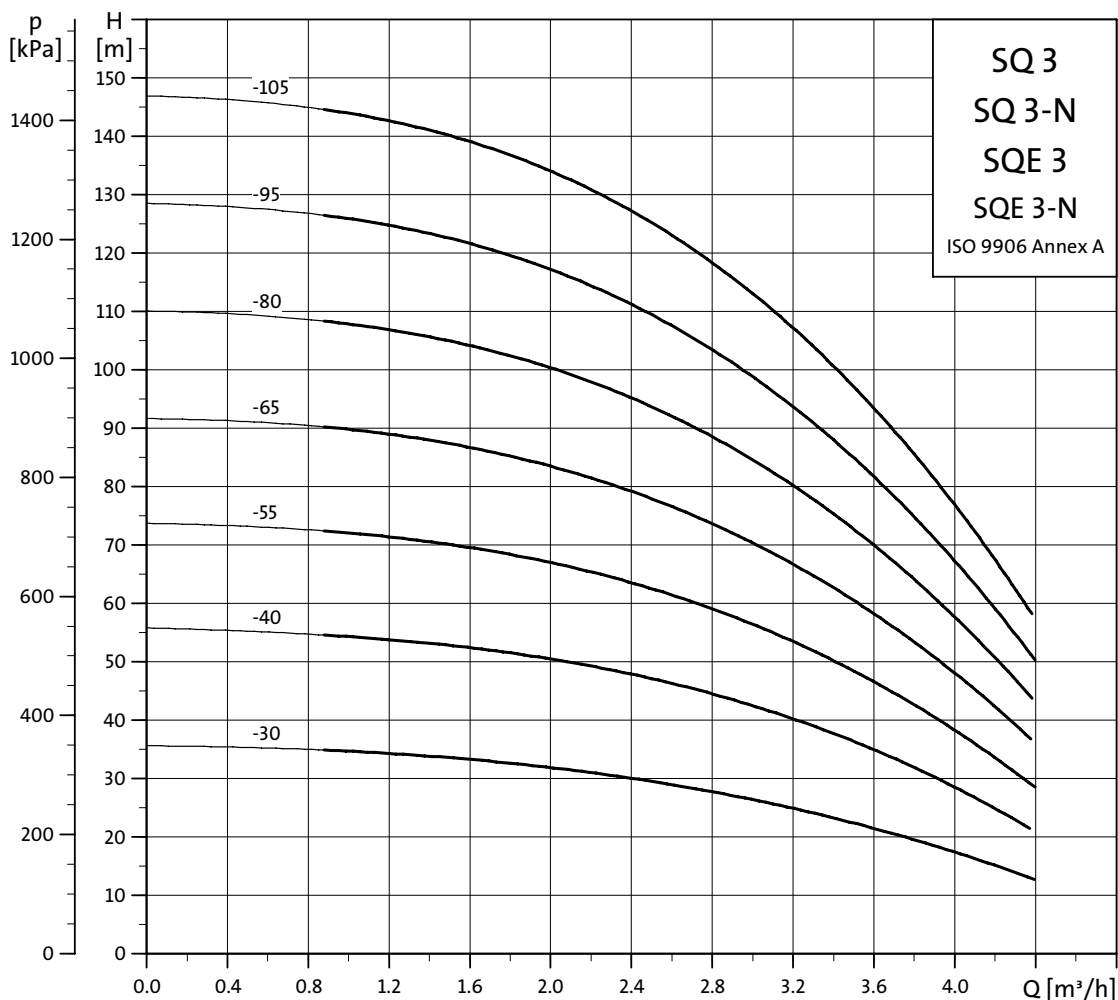

TM01 2694 4304

## Dimensions and weights

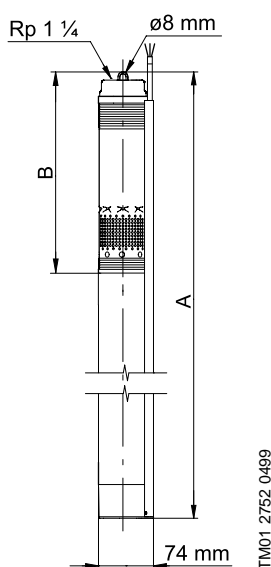

Pump type	Number of stages	Motor		Dimensions [mm]		Net weight [kg]*	Shipping volume [m <sup>3</sup> ]*
		Type	Output power (P <sub>2</sub> ) [kW]	A	B		
SQ 3 - 30 (-N)	2	MS 3 (-NE)	0.70	741	265	4.8	0.0092
SQE 3 - 30 (-N)		MSE 3 (-NE)					
SQ 3 - 40 (-N)	3	MS 3 (-NE)	0.70	741	265	4.8	0.0092
SQE 3 - 40 (-N)		MSE 3 (-NE)					
SQ 3 - 55 (-N)	4	MS 3 (-NE)	1.15	768	292	5.4	0.0094
SQE 3 - 55 (-N)		MSE 3 (-NE)					
SQ 3 - 65 (-N)	5	MS 3 (-NE)	1.15	825	346	6.1	0.0100
SQE 3 - 65 (-N)		MSE 3 (-NE)					
SQ 3 - 80 (-N)	6	MS 3 (-NE)	1.68	861	346	6.3	0.0104
SQE 3 - 80 (-N)		MSE 3 (-NE)					
SQ 3 - 95 (-N)	7	MS 3 (-NE)	1.68	888	373	6.4	0.0107
SQE 3 - 95 (-N)		MSE 3 (-NE)					
SQ 3 - 105 (-N)	8	MS 3 (-NE)	1.85	942	427	6.5	0.0113
SQE 3 - 105 (-N)		MSE 3 (-NE)					

\* Including pump, motor, 1.5 m cable and cable guard.

## Electrical data

1 x 200 - 240 V, 50/60 Hz

Pump type	Motor type	Input power, motor (P <sub>1</sub> ) [kW]	Output power motor (P <sub>2</sub> ) [kW]	Required input power, pump [kW]	Full load current I <sub>1/1</sub> [A]		Full load motor efficiency (η) [%]
					230 V	200 V	
SQ 3 - 30 (-N)	MS 3 (-NE)	0.67	0.70	0.44	2.9	3.4	70
SQE 3 - 30 (-N)	MSE 3 (-NE)						
SQ 3 - 40 (-N)	MS 3 (-NE)	0.93	0.70	0.63	4.0	4.8	70
SQE 3 - 40 (-N)	MSE 3 (-NE)						
SQ 3 - 55 (-N)	MS 3 (-NE)	1.17	1.15	0.83	5.1	5.9	73
SQE 3 - 55 (-N)	MSE 3 (-NE)						
SQ 3 - 65 (-N)	MS 3 (-NE)	1.42	1.15	1.02	6.2	7.2	73
SQE 3 - 65 (-N)	MSE 3 (-NE)						
SQ 3 - 80 (-N)	MS 3 (-NE)	1.72	1.68	1.23	7.4	8.8	74
SQE 3 - 80 (-N)	MSE 3 (-NE)						
SQ 3 - 95 (-N)	MS 3 (-NE)	1.97	1.68	1.43	8.4	10.1	74
SQE 3 - 95 (-N)	MSE 3 (-NE)						
SQ 3 - 105 (-N)	MS 3 (-NE)	2.19	1.85	1.63	9.7	11.0	74
SQE 3 - 105 (-N)	MSE 3 (-NE)						

## SQ 5, SQ 5-N, SQE 5, SQE 5-N

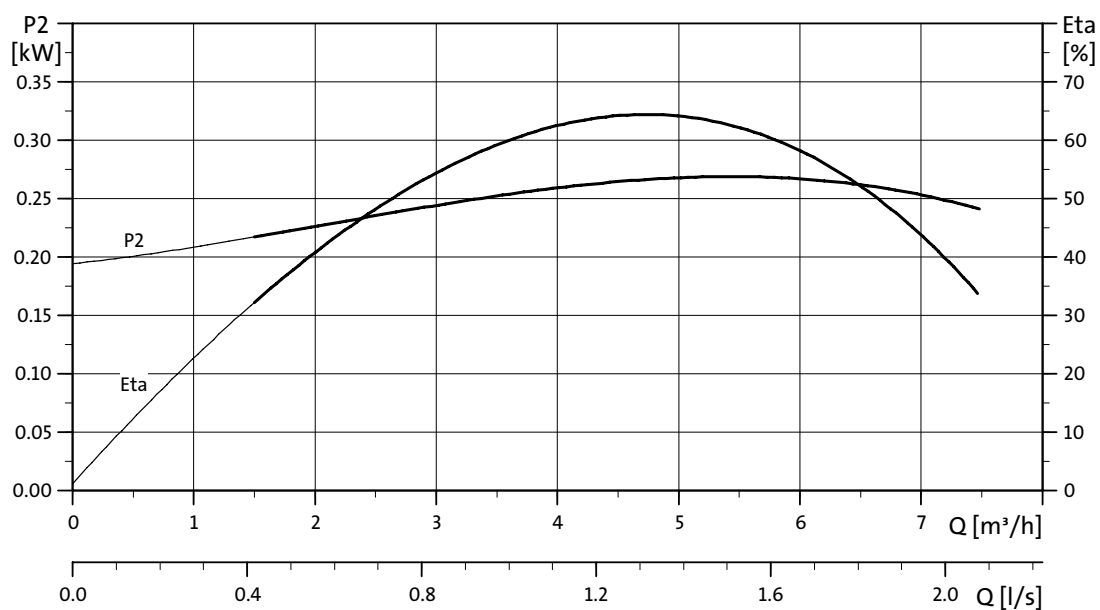
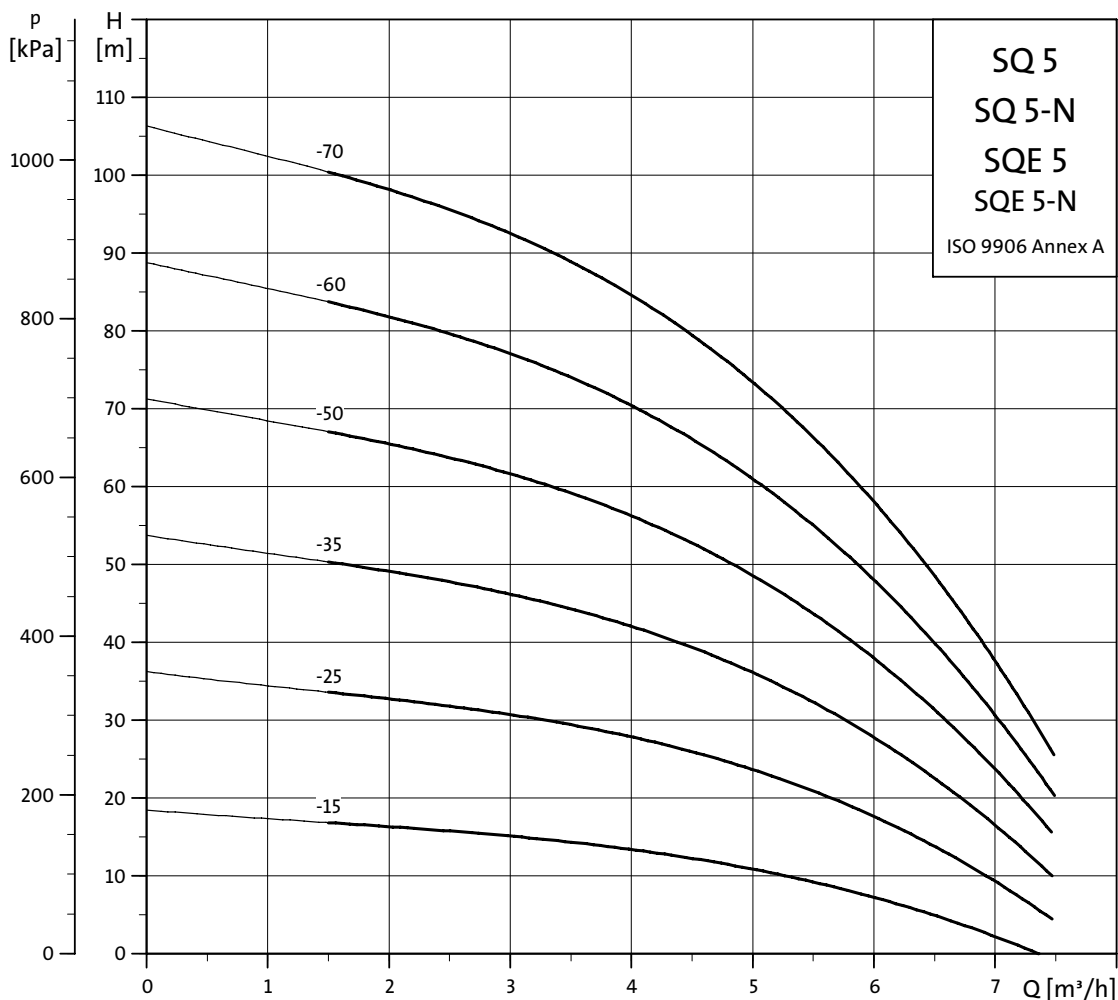

TM01 2695 4304

## Dimensions and weights

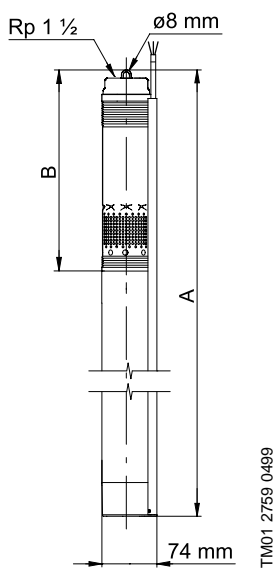

Pump type	Number of stages	Motor		Dimensions [mm]		Net weight [kg]*	Shipping volume [m <sup>3</sup> ]*
		Type	Output power (P <sub>2</sub> ) [kW]	A	B		
SQ 5 - 15 (-N)	1	MS 3 (-NE)	0.70	743	265	4.7	0.0092
SQE 5 - 15 (-N)		MSE 3 (-NE)					
SQ 5 - 25 (-N)	2	MS 3 (-NE)	0.70	743	265	4.8	0.0092
SQE 5 - 25 (-N)		MSE 3 (-NE)					
SQ 5 - 35 (-N)	3	MS 3 (-NE)	1.15	824	346	5.5	0.0100
SQE 5 - 35 (-N)		MSE 3 (-NE)					
SQ 5 - 50 (-N)	4	MS 3 (-NE)	1.68	860	346	6.1	0.0104
SQE 5 - 50 (-N)		MSE 3 (-NE)					
SQ 5 - 60 (-N)	5	MS 3 (-NE)	1.68	941	427	6.4	0.0113
SQE 5 - 60 (-N)		MSE 3 (-NE)					
SQ 5 - 70 (-N)	6	MS 3 (-NE)	1.85	941	427	6.4	0.0113
SQE 5 - 70 (-N)		MSE 3 (-NE)					

\* Including pump, motor, 1.5 m cable and cable guard.

## Electrical data

1 x 200 - 240 V, 50/60 Hz

Pump type	Motor type	Input power, motor (P <sub>1</sub> ) [kW]	Output power motor (P <sub>2</sub> ) [kW]	Required input power, pump [kW]	Full load current I <sub>1/1</sub> [A]		Full load motor efficiency (η) [%]
					230 V	200 V	
SQ 5 - 15 (-N)	MS 3 (-NE)	0.44	0.70	0.26	1.9	2.2	70
SQE 5 - 15 (-N)	MSE 3 (-NE)						
SQ 5 - 25 (-N)	MS 3 (-NE)	0.80	0.70	0.54	3.4	4.1	70
SQE 5 - 25 (-N)	MSE 3 (-NE)						
SQ 5 - 35 (-N)	MS 3 (-NE)	1.13	1.15	0.80	4.9	5.7	70
SQE 5 - 35 (-N)	MSE 3 (-NE)						
SQ 5 - 50 (-N)	MS 3 (-NE)	1.50	1.68	1.06	6.5	7.7	74
SQE 5 - 50 (-N)	MSE 3 (-NE)						
SQ 5 - 60 (-N)	MS 3 (-NE)	1.84	1.68	1.33	7.9	9.4	74
SQE 5 - 60 (-N)	MSE 3 (-NE)						
SQ 5 - 70 (-N)	MS 3 (-NE)	2.15	1.85	1.60	9.5	10.8	74
SQE 5 - 70 (-N)	MSE 3 (-NE)						

## SQ 7, SQ 7-N, SQE 7, SQE 7-N

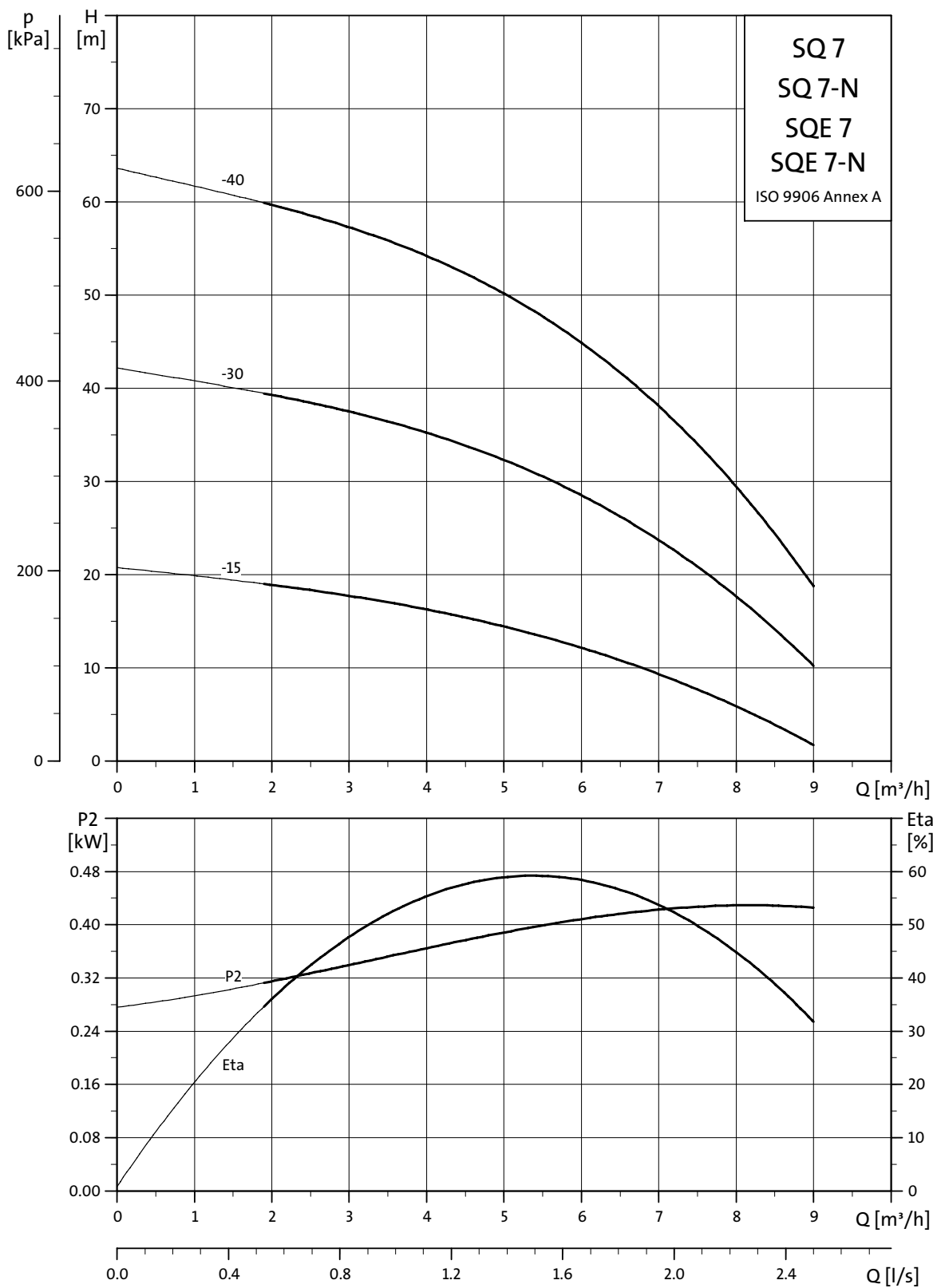

TM01 2696 4304



## Dimensions and weights

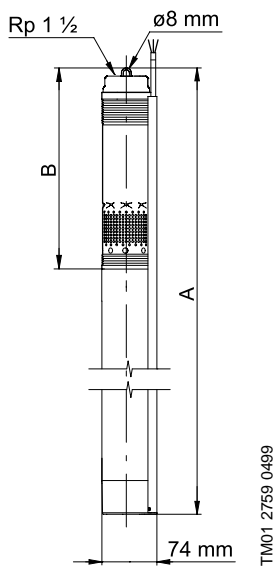

Pump type	Number of stages	Motor		Dimensions [mm]		Net weight [kg]*	Shipping volume [m <sup>3</sup> ]*
		Type	Output power (P <sub>2</sub> ) [kW]	A	B		
SQ 7 - 15 (-N)	1	MS 3 (-NE)	0.7	743	265	4.7	0.0092
SQE 7 - 15 (-N)		MSE 3 (-NE)					
SQ 7 - 30 (-N)	2	MS 3 (-NE)	1.15	743	265	5.2	0.0092
SQE 7 - 30 (-N)		MSE 3 (-NE)					
SQ 7 - 40 (-N)	3	MS 3 (-NE)	1.68	860	346	6.1	0.0104
SQE 7 - 40 (-N)		MSE 3 (-NE)					

\* Including pump, motor, 1.5 m cable and cable guard.

## Electrical data

1 x 200 - 240 V, 50/60 Hz

Pump type	Motor type	Input power, motor (P <sub>1</sub> ) [kW]	Output power motor (P <sub>2</sub> ) [kW]	Required input power, pump [kW]	Full load current I <sub>1/1</sub> [A]		Full load motor efficiency (η) [%]
					230 V	200 V	
SQ 7 - 15 (-N)	MS 3 (-NE)	0.65	0.70	0.42	2.8	3.3	70
SQE 7 - 15 (-N)	MSE 3 (-NE)						
SQ 7 - 30 (-N)	MS 3 (-NE)	1.18	1.15	0.84	5.2	6.0	73
SQE 7 - 30 (-N)	MSE 3 (-NE)						
SQ 7 - 40 (-N)	MS 3 (-NE)	1.77	1.68	1.27	7.6	9.1	74
SQE 7 - 40 (-N)	MSE 3 (-NE)						

## Pump, SQ and SQE

<b>Mains supply to pump</b>	1 x 200-240 V -10%/+6%, 50/60 Hz, PE.
<b>Starting</b>	Soft starting.
<b>Stopping</b>	Soft stopping when stopped by the CU 300 or CU 301.
<b>Run-up time</b>	Maximum: 3 seconds. No limitation to the number of starts/stops per hour.
<b>Motor protection</b>	Built into the pump. Protection against: <b>Dry running.</b> <b>Overvoltage and undervoltage, cuts out below 150 V and above 315 V.</b> <b>Overload.</b> <b>Overtemperature.</b>
<b>Sound pressure level</b>	The sound pressure level is lower than the limiting values stated in the EEC Machinery Directive.
<b>Radio noise</b>	SQ and SQE comply with EMC Directive 89/336/EEC. Approved according to EN 50081-1 and 50082-2.
<b>Reset function</b>	SQE pumps can be reset via CU 300 or via CU 301 (possibly by means of R100).
<b>Power factor</b>	PF = 1.
<b>Operation via generator</b>	It is recommended that the generator output is equal to the motor input power $P_1$ [kW] plus 50%; min. $P_1$ +10%, however.
<b>Earth leakage circuit breaker</b>	If the pump is connected to an electrical installation where an earth-leakage circuit breaker (ELCB) is used as an additional protection, this circuit breaker must trip out when earth fault currents with DC content (pulsating DC) occur.
<b>Pipe connection</b>	SQ 1, SQ 2, SQ 3 : Rp 1¼. SQ 5, SQ 7: Rp 1½.
<b>Borehole diameter</b>	Minimum: 76 mm.
<b>Installation depth</b>	Maximum: 150 m below the static water table (15 bar). For horizontal installation flow sleeve is recommended. Installation depth below dynamic water level: Vertical installation with/without flow sleeve: 0.5 m. Horizontal installation with/without flow sleeve: 0.5 m.
<b>NPSH</b>	Max. 8 m.
<b>Strainer</b>	Holes of the strainer: $\varnothing$ 2.3 mm.
<b>Pumped liquids</b>	SQ, SQE (DIN W.-Nr. 1.4301), SQ-N (DIN W.-Nr. 1.4401): pH 5 to 9. Sand content up to 50 g/m <sup>3</sup> .

## Control units, CU 300 and CU 301

<b>Voltage</b>	1 x 100-240 V -10%/+6%, 50/60 Hz, PE.
<b>Power consumption</b>	5 W.
<b>Current consumption</b>	Maximum 130 mA.
<b>Enclosure class</b>	IP 55.
<b>Ambient temperature</b>	In operation: -30°C to +50°C, during storage -30°C to +60°C.
<b>Relative air humidity</b>	95%.
<b>Pump cable</b>	Maximum length between CU 300 or CU 301 and pump: 200 m.
<b>Back-up fuse</b>	Maximum: 16 A.
<b>Radio noise</b>	CU 300 and CU 301 comply with EMC Directive 89/336/EEC. Approved according to the standards EN 55 014 and 55 014-2.
<b>Marking</b>	CE.
<b>Load</b>	Max. 100 mA.

## Material specification (Pump)

Pos.	Component	Material	DIN W.-Nr. SQ/SQE	AISI	DIN W.-Nr. SQ-N SQE-N	AISI
1	Valve casing	Polyamide				
1a	Discharge chamber	Stainless steel	1.4301	304	1.4401	316
1d	O-ring	NBR rubber				
2	Valve cup	Polyamide				
3	Valve seat	NBR rubber				
4a	Empty chamber	Polyamide				
6	Top bearing	NBR rubber				
7	Neck ring	TPU/PBT				
7a	Lock ring	Stainless spring steel	1.4310	310	1.4404	316
7b	Neck ring retainer	Polyamide				
9b	Chamber top	Polyamide				
9c	Chamber bottom	Polyamide				
13	Impeller with tungsten carbide bearing	Polyamide				
14	Suction interconnector	Polyamide				
14a	Ring	Stainless steel	1.4301	304	1.4401	316
16	Shaft with coupling	Stainless steel Sintered steel	1.4301	304	1.4401	316
18	Cable guard	Stainless steel	1.4301	304	1.4401	316
18a	Screws for cable guard	Stainless steel	1.4401	316	1.4401	316
30	Cone for pressure equalisation	Polyamide				
32	Guide vanes	Polyamide				
39	Spring	Stainless spring steel	1.4406	316 LN	1.4406	316 LN
55	Pump sleeve	Stainless steel	1.4301	304	1.4401	316
64	Priming screw	Polyamide				
70	Valve guide	Polyamide				
86	Lip seal ring	NBR rubber				
87	Cone for pressure equalization complete	Polyamide/NBR rubber				

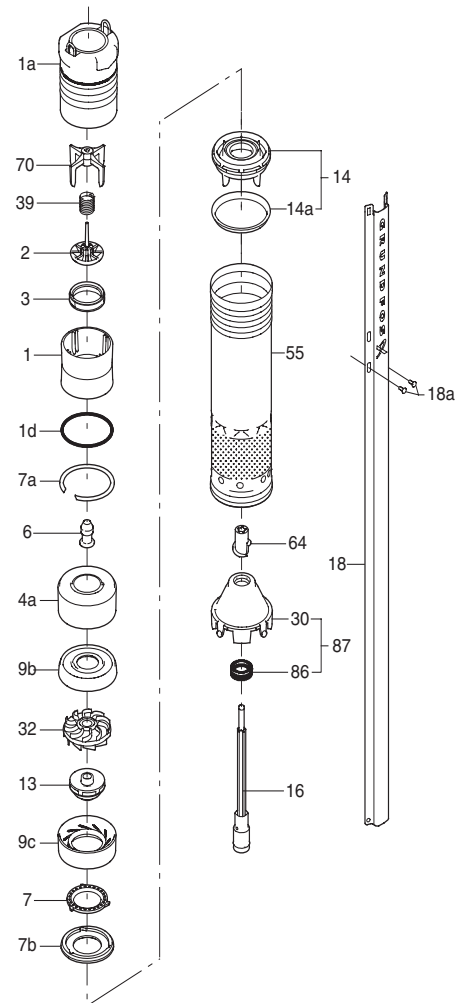

## Material specification (Motor)

Pos.	Component	Material	DIN W.-Nr. MS 3/ MSE 3	AISI	DIN W.-Nr. MS 3-NE	AISI
201	Stator	Stainless steel	1.4301	304	1.4401	316
220	Motor cable with plug	EPR				
222a	Filling plug	MS 3: NBR MSE 3-NE: FKM				
225	Top cover	PPS				
	Motor liquid	SML-2				

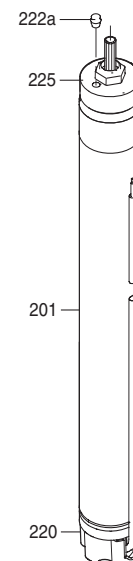

TM01 2745 0706

## Wiring diagrams

### Mains connection of pump via pressure switch

The pressure switch must be rated to the max. amps of the specific pump size.

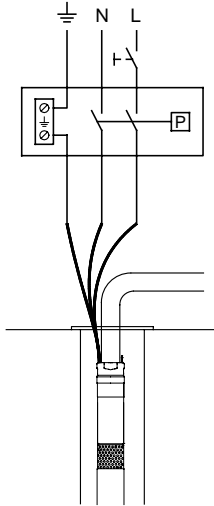

TM01 1480 4697

### Electrical connection of CU 300

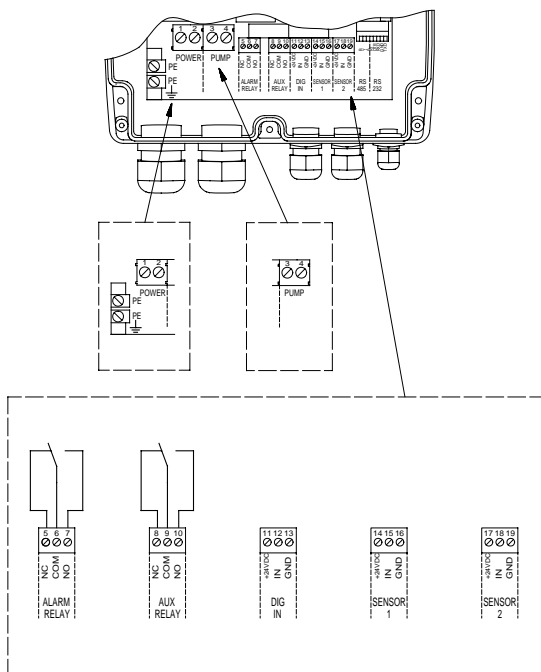

TM01 3008 2898

#### Alarm relay:

Potential-free changeover contact  
Maximum contact load: AC 250 V, Max. current 1A  
Minimum contact load: DC 5 V, 10 mA

#### Auxiliary relay:

Potential-free changeover contact  
Maximum contact load: Safety extra-low voltage to be used only.  
Max. current 1A  
Minimum contact load: DC 5 V, 10 mA

#### Digital input:

External potential-free contact  
Logic "0":  $U_{in} > 3.2 V$   
Logic "1":  $U_{in} < 0.9 V$

#### Sensor 1:

Voltage signal: DC 0 - 10 V/2 - 10 V,  $R_i = 11 k\Omega$ .  
Tolerance:  $\pm 3\%$  at maximum voltage signal.  
Screened cable recommended, maximum length of cable: 500 m.  
Current signal: DC 0 - 20 mA/4 - 20 mA,  $R_i = 500 \Omega$ .  
Tolerance:  $\pm 3\%$  at maximum current signal.  
Screened cable recommended, maximum length of cable: 500 m.

#### Sensor 2:

Potentiometer: DC 0 - 24 V, 10 k $\Omega$  (via internal voltage supply).  
Screened cable recommended, maximum length of cable: 100 m.

Voltage signal: DC 0 - 10 V/2-10 V,  $R_i = 11 k\Omega$ .

Tolerance:  $\pm 3\%$  at maximum voltage signal.  
Screened cable recommended, maximum length of cable: 500 m.

Current signal: DC 0 - 20 mA/4 - 20 mA,  $R_i = 500 \Omega$ .

Tolerance:  $\pm 3\%$  at maximum current signal.  
Screened cable recommended, maximum length of cable: 500 m.

## Electrical connection of CU 301

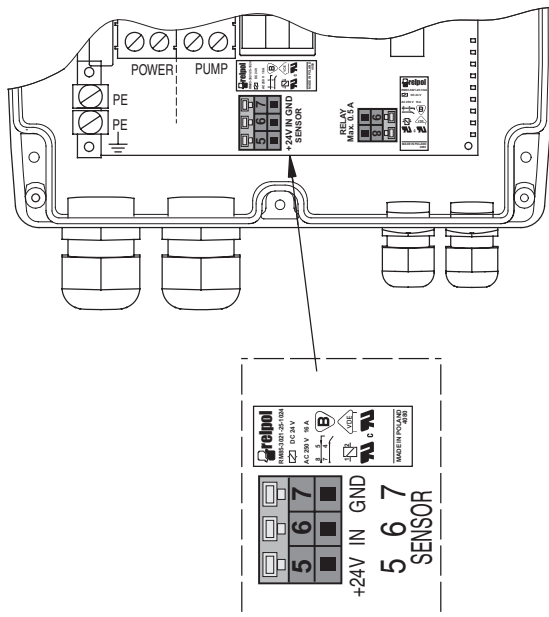

TM03 3430 0406

### Sensor:

Voltage signal: DC 0 - 10 V/2 - 10 V,  $R_i = 11 \text{ k}\Omega$ .

Tolerance:  $\pm 3\%$  at maximum voltage signal.

Screened cable recommended, maximum length of cable: 500 m.

Current signal: DC 0 - 20 mA/4 - 20 mA,  $R_i = 500 \Omega$ .

Tolerance:  $\pm 3\%$  at maximum current signal.

Screened cable recommended, maximum length of cable: 500 m.

Product number for the pressure

sensor, 4-20 mA, 0-6 bar: 96437851.

### Operating relay:

The operating relay is a normally open (NO) contact, the relay is activated when the pump is running.

- Max 0,5 A
- Maximum voltage 230 VAC

## Constant-pressure packages incl. pump

Contents	Pump type	Cable length	Product no.
One constant-pressure package includes: - Pump, SQE incl. cable - Control unit, CU 301 - Tank, 8 litres - Pressure sensor, PT 0-6 bar - Pressure gauge, 10 bar, ø63 - Ball valve, 3/4" - Cable clips, 20 pieces	SQE 2-55	40 m	96524505
	SQE 2-85	60 m	96524506
	SQE 2-115	80 m	96524507
	SQE 3-65	20 m	96524502
	SQE 3-65	40 m	96524501
	SQE 3-105	80 m	96524508
	SQE 5-50	40 m	96524509
	SQE 5-70	40 m	96524503

## Constant-pressure package excl. pump

Contents	Product no.
- Control unit, CU 301 - Tank, 8 litres - Pressure sensor, PT 0-6 bar - Pressure gauge, 10 bar, ø63 - Ball valve, 3/4" - Cable clips, 20 pieces	96524504

**Note:** The Flex package can be used with all SQE pumps.

Contents	Product no.
- Tank, 18 litres - Presscontrol PC 15 - Pressure gauge, 6 bar - Tee-piece (to be used when fitting the pressure gauge).	96037331

## CU 301

Product	Product number
CU 301	96436753 (Europe)

## Pressure sensor for CU 301

Product	Measuring range	Product number
Pressure sensor kit incl. 2 m cable	0 - 6 bar	96437851

## CU 300

Product	Product number
CU 300	96422775 (English)

Language specific CU 300 versions available on request.

## Submersible drop cable



TM00 7882 2296

Description	Version	Nominal diameter [mm]	Product no.
3-core cable incl. earth conductor KTW approved. When ordering please state length [m]	3G 1.5 mm <sup>2</sup> (round)	9.6 - 12.5	ID7946
	3G 2.5 mm <sup>2</sup> (round)	11.5 - 14.5	ID7947
	3G 4.0 mm <sup>2</sup> (round)	13.0 - 16.0	ID7948
	3G 6.0 mm <sup>2</sup> (round)	14.5 - 20.0	RM4098
	3G x 1.5 mm <sup>2</sup> (flat)	6.5 - 13.2	RM3952

## Cable termination kit, type KM

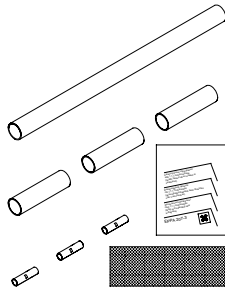

TM03 0181 4404

Description	Cross section of leads [mm <sup>2</sup> ]	Product no.
For watertight shrink-joining of motor cable and submersible drop cable (round or flat cable).		
Enables the joining of:		
- cables of equal size.	1.5 - 2.5 mm <sup>2</sup>	96021462
- cables of different size.	4.0 - 6.0 mm <sup>2</sup>	96021473
- cable leads with single leads.		
The joint is ready for use after a few minutes and requires no long hardening time as do resin joints.		
The joint cannot be separated.		

## Cable clips



TM00 4179 1994

Description	Nominal diameter [mm]	Product no.
For fastening of cable and straining wire to the riser pipe.		
The clips should be fitted every 3 metres	length = 7.5 m	00115016
One set for approx. 45 m riser pipe.	16 buttons	

## Pressure tank

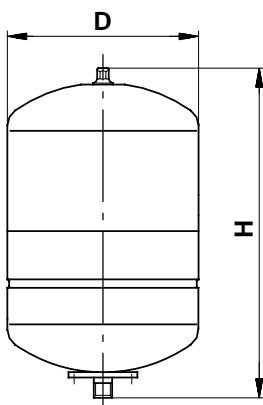

TM02 7934 4403

Duty range						
Precharge pressure:	1½ bar					
Max. Operating pressure:	10 bar					
Max. liquid temperature:	+99°C					
Flange material:	Stainless steel					
Description	Connection	D [mm]	H [mm]	Weight [kg]	Product no.	
8 litres	G ¾	202	303	2.3	96528335	
18 litres	G ¾	279	367	4.6	96526322	
24 litres	G 1	289	447	5.1	96528339	
33 litres	G 1	289	584	6.7	96528340	
60 litres*	G 1	397	557	11.0	96528341	
80 litres*	G 1	397	755	16.0	96528342	

\* For installation on the floor. Fitted with 90° elbow.

## Pressure gauge

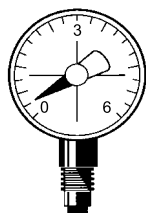

TM01 3092 3498

Measuring range	Connection G	Diameter [mm]	Product no.
0 - 6 bar	¼	50	ID3266
0 - 10 bar	¼	63	ID8048

## Straining wire



TM00 7897 2296

Description	Diameter	Product no.
Stainless steel DIN W.-Nr. 1.4401. Retains the submersible pump. When ordering please state length [m].	2 mm	00ID8957

## Wire clamp



TM00 7898 2296

Description	Version	Product no.
Stainless steel DIN W.-Nr. 1.4401.	Two clamps per loop	00ID8960

## Flow sleeve

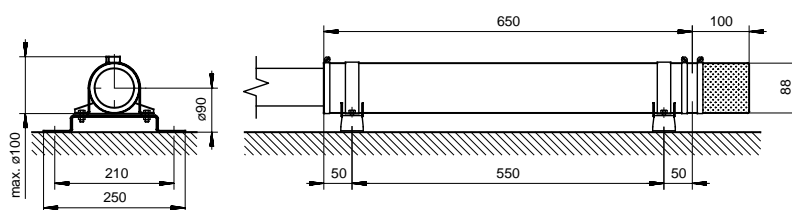

TM01 3292 3798

Description	Material	Product no.
Flow sleeve	DIN W.-Nr. 1.4301	91071933
Strainer	DIN W.-Nr. 1.4301	91071934
Supporting brackets	DIN W.-Nr. 1.4301	91071935



## Presscontrol



TM01 3131 3498

Description	Version	Product no.
Presscontrol PC 15 for automatic SQ-operation. 1.5 bar, without plug.		
Max. pressure: 10 bar.	1 x 220-240 V	465322
See page 10 for further information.		

## R100 remote control

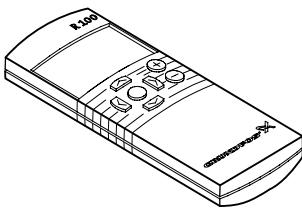

TM00 8367 4801

Description	Product no.
The R100 is used for wireless communication with CU 300 and CU 301. Communication takes place by means of infrared light.	625333

## Printer

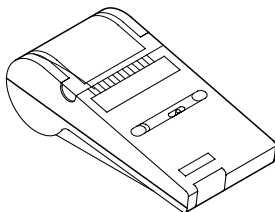

TM00 8368 2796

Description	Product no.
Printer for R100, infrared communication, Type: Hewlett Packard, HP 82240B.	620480
Paper roll.	620481

## Potentiometer, SPP 1

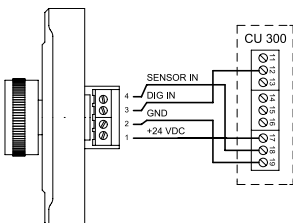
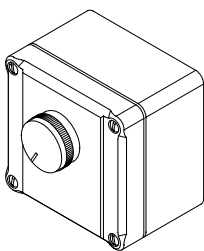

TM00 2604 4793 - TM01 3291 3798

Description	Version	Product no.
External potentiometer with cabinet for wall mounting. Screened cables, 4-wire cable. Max. length of cable: 100 m.	Grundfos potentiometer, SPP 1. Enclosure class: IP 55	625468

## SQE Speed Calculation program

Description	Product no.
<ul style="list-style-type: none"> <li>SQE Speed calculation program CD-ROM</li> <li>Operating manual.</li> </ul>	96478266

## Sensors

Sensors	Supplier	Type	Measuring Range	Product no.
Level sensor, incl. 30 m cable	JUMO	4390-242	0 - 2.5 bar	96037489
Level sensor, incl. 65 m cable	JUMO	4390-242	0 - 6 bar	96037490
Level sensor, incl. 105 m cable	JUMO	4390-242	0 - 10 bar	96037491
Pressure switch	Condor	mdr 21/6	1 - 6 bar	ID6462
Flow switch unit (SQE 1, SQE 2, SQE 3)	Grundfos	mdr 21/6 1"	0 - 5 m <sup>3</sup> /h	96037332
Flow switch unit (SQE 5, SQE 7)	Grundfos	FS 200	5 - 7 m <sup>3</sup> /h	96037559
Flow meter (pulsating) 1 l/pulse	Bdr. Dahl	QN 2.5	0 - 5 m <sup>3</sup> /h	96037492
Flow meter (pulsating) 2.5 l/pulse	Bdr. Dahl	QN 6	0 - 12 m <sup>3</sup> /h	96037583
Flow meter (pulsating) 5 l/pulse	Bdr. Dahl	QN 10	0 - 20 m <sup>3</sup> /h	96037584
Pressure sensor kit for CU 300 incl. 2 m cable	Danfoss	MBS 3000	0 - 4 bar	405160
			0 - 6 bar	405161
Pressure sensor kit for CU 301 incl. 2 m cable	Grundfos	Grundfos type	0 - 6 bar	96437851

## Complete units 1 x 200-240 V with 1.5 m cable

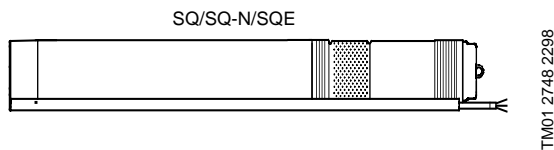

### Complete unit: SQ 1, SQ 1-N, SQE 1, SQE 1-N

Pump type	Motor		Product number
	Type	Output power motor (P <sub>2</sub> ) [kW]	
SQ 1 - 35	MS 3	0.70	96510178
SQ 1 - 35 N	MS 3 - NE	0.70	96160370
SQE 1 - 35	MSE 3	0.70	96510071
SQE 1 - 35 N	MSE 3 - NE	0.70	96160436
SQ 1 - 50	MS 3	0.70	96510179
SQ 1 - 50 N	MS 3 - NE	0.70	96160371
SQE 1 - 50	MSE 3	0.70	96510141
SQE 1 - 50 N	MSE 3 - NE	0.70	96160437
SQ 1 - 65	MS 3	0.70	96510190
SQ 1 - 65 N	MS 3 - NE	0.70	96160372
SQE 1 - 65	MSE 3	0.70	96510142
SQE 1 - 65 N	MSE 3 - NE	0.70	96160438
SQ 1 - 80	MS 3	1.15	96510191
SQ 1 - 80 N	MS 3 - NE	1.15	96160373
SQE 1 - 80	MSE 3	1.15	96510143
SQE 1 - 80 N	MSE 3 - NE	1.15	96160439
SQ 1 - 95	MS 3	1.15	96510192
SQ 1 - 95 N	MS 3 - NE	1.15	96160374
SQE 1 - 95	MSE 3	1.15	96510144
SQE 1 - 95 N	MSE 3 - NE	1.15	96160440
SQ 1 - 110	MS 3	1.15	96510193
SQ 1 - 110 N	MS 3 - NE	1.15	96160375
SQE 1 - 110	MSE 3	1.15	96510145
SQE 1 - 110 N	MSE 3 - NE	1.15	96160441
SQ 1 - 125	MS 3	1.68	96510194
SQ 1 - 125 N	MS 3 - NE	1.68	96160376
SQE 1 - 125	MSE 3	1.68	96510146
SQE 1 - 125 N	MSE 3 - NE	1.68	96160442
SQ 1 - 140	MS 3	1.68	96510195
SQ 1 - 140 N	MS 3 - NE	1.68	96160377
SQE 1 - 140	MSE 3	1.68	96510147
SQE 1 - 140 N	MSE 3 - NE	1.68	96160443
SQ 1 - 155	MS 3	1.85	96510196
SQ 1 - 155 N	MS 3 - NE	1.85	96160378
SQE 1 - 155	MSE 3	1.85	96510148
SQE 1 - 155 N	MSE 3 - NE	1.85	96160444

## Complete unit: SQ 2, SQ 2-N, SQE 2, SQE 2-N

Pump type	Motor		Product number
	Type	Output power motor (P <sub>2</sub> ) [kW]	
SQ 2 - 35	MS 3	0.70	96510198
SQ 2 - 35 N	MS 3 - NE	0.70	96160379
SQE 2 - 35	MSE 3	0.70	96510150
SQE 2 - 35 N	MSE 3 -	0.70	96160445
SQ 2 - 55	MS 3	0.70	96510199
SQ 2 - 55 N	MS 3 - NE	0.70	96160380
SQE 2 - 55	MSE 3	0.70	96510151
SQE 2 - 55 N	MSE 3 -	0.70	96160446
SQ 2 - 70	MS 3	1.15	96510200
SQ 2 - 70 N	MS 3 - NE	1.15	96160381
SQE 2 - 70	MSE 3	1.15	96510152
SQE 2 - 70 N	MSE 3 -	1.15	96160447
SQ 2 - 85	MS 3	1.15	96510201
SQ 2 - 85 N	MS 3 - NE	1.15	96160382
SQE 2 - 85	MSE 3	1.15	96510153
SQE 2 - 85 N	MSE 3 -	1.15	96160448
SQ 2 - 100	MS 3	1.68	96510202
SQ 2 - 100 N	MS 3 - NE	1.68	96160383
SQE 2 - 100	MSE 3	1.68	96510154
SQE 2 - 100 N	MSE 3 -	1.68	96160449
SQ 2 - 115	MS 3	1.85	96510203
SQ 2 - 115 N	MS 3 - NE	1.85	96160384
SQE 2 - 115	MSE 3	1.85	96510155
SQE 2 - 115 N	MSE 3 -	1.85	96160450

## Complete unit: SQ 3, SQ 3-N, SQE 3, SQE 3-N

Pump type	Motor		Product number
	Type	Output power motor (P <sub>2</sub> ) [kW]	
SQ 3 - 30	MS 3	0.70	96510204
SQ 3 - 30 N	MS 3 - NE	0.70	96160386
SQE 3 - 30	MSE 3	0.70	96510156
SQE 3 - 30 N	MSE 3 -	0.70	96160452
SQ 3 - 40	MS 3	0.70	96510205
SQ 3 - 40 N	MS 3 - NE	0.70	96160387
SQE 3 - 40	MSE 3	0.70	96510157
SQE 3 - 40 N	MSE 3 -	0.70	96160453
SQ 3 - 55	MS 3	1.15	96510206
SQ 3 - 55 N	MS 3 - NE	1.15	96160388
SQE 3 - 55	MSE 3	1.15	96510158
SQE 3 - 55 N	MSE 3 -	1.15	96160454
SQ 3 - 65	MS 3	1.15	96510207
SQ 3 - 65 N	MS 3 - NE	1.15	96160389
SQE 3 - 65	MSE 3	1.15	96510159
SQE 3 - 65 N	MSE 3 -	1.15	96160455
SQ 3 - 80	MS 3	1.68	96510208
SQ 3 - 80 N	MS 3 - NE	1.68	96160390
SQE 3 - 80	MSE 3	1.68	96510160
SQE 3 - 80 N	MSE 3 -	1.68	96160456
SQ 3 - 95	MS 3	1.68	96510209
SQ 3 - 95 N	MS 3 - NE	1.68	96160391
SQE 3 - 95	MSE 3	1.68	96510161
SQE 3 - 95 N	MSE 3 -	1.68	96160457
SQ 3 - 105	MS 3	1.85	96510210
SQ 3 - 105 N	MS 3 - NE	1.85	96160392
SQE 3 - 105	MSE 3	1.85	96510162
SQE 3 - 105 N	MSE 3 -	1.85	96160458

## Complete unit: SQ 5, SQ 5-N, SQE 5, SQE 5-N

Pump type	Motor		Product number
	Type	Output power motor (P <sub>2</sub> ) [kW]	
SQ 5 - 15	MS 3	0.70	96510211
SQ 5 - 15 N	MS 3 - NE	0.70	96160393
SQE 5 - 15	MSE 3	0.70	96510163
SQE 5 - 15 N	MSE 3 - NE	0.70	96160459
SQ 5 - 25	MS 3	0.70	96510212
SQ 5 - 25 N	MS 3 - NE	0.70	96160394
SQE 5 - 25	MSE 3	0.70	96510164
SQE 5 - 25 N	MSE 3 - NE	0.70	96160460
SQ 5 - 35	MS 3	1.15	96510213
SQ 5 - 35 N	MS 3 - NE	1.15	96160395
SQE 5 - 35	MSE 3	1.15	96510165
SQE 5 - 35 N	MSE 3 - NE	1.15	96160461
SQ 5 - 50	MS 3	1.68	96510214
SQ 5 - 50 N	MS 3 - NE	1.68	96160396
SQE 5 - 50	MSE 3	1.68	96510166
SQE 5 - 50 N	MSE 3 - NE	1.68	96160462
SQ 5 - 60	MS 3	1.68	96510215
SQ 5 - 60 N	MS 3 - NE	1.68	96160397
SQE 5 - 60	MSE 3	1.68	96510167
SQE 5 - 60 N	MSE 3 - NE	1.68	96160463
SQ 5 - 70	MS 3	1.85	96510217
SQ 5 - 70 N	MS 3 - NE	1.85	96160398
SQE 5 - 70	MSE 3	1.85	96510168
SQE 5 - 70 N	MSE 3 - NE	1.85	96160464

## Complete unit: SQ 7, SQ 7-N, SQE 7, SQE 7-N

Pump type	Motor		Product number
	Type	Output power motor (P <sub>2</sub> ) [kW]	
SQ 7 - 15	MS 3	0.70	96510218
SQ 7 - 15 N	MS 3 - NE	0.70	96160399
SQE 7 - 15	MSE 3	0.70	96510169
SQE 7 - 15 N	MSE 3 - NE	0.70	96160465
SQ 7 - 30	MS 3	1.15	96510219
SQ 7 - 30 N	MS 3 - NE	1.15	96160400
SQE 7 - 30	MSE 3	1.15	96510170
SQE 7 - 30 N	MSE 3 - NE	1.15	96160466
SQ 7 - 40	MS 3	1.68	96510220
SQ 7 - 40 N	MS 3 - NE	1.68	96160401
SQE 7 - 40	MSE 3	1.68	96510171
SQE 7 - 40 N	MSE 3 - NE	1.68	96160467

## Submersible drop cables

The submersible drop cables are approved for use in drinking water (KTW approved). The material of the submersible drop cable is EPR.

The table below shows the maximum length of the submersible drop cable for the different sizes of cross-section of the leads according to a 4% voltage drop IEC 3-64, HD-384 series or regulations set by the local authorities. If the pump operates at a higher voltage drop the pump performance will be reduced. The pump will be cut out if voltage falls below 150 V.

### Max. cable lengths:

Output power motor (P <sub>2</sub> ) [kW]	I <sub>1/1</sub> [A]	Max. length [m]			
		1.5 mm <sup>2</sup>	2.5 mm <sup>2</sup>	4 mm <sup>2</sup>	6 mm <sup>2</sup>
0.7	5.2	69	115	185	277
1.15	8.4	43	71	114	171
1.68	11.2	32	54	86	129
1.85	12.0	30	50	80	120

The table values are calculated on the basis of the formula:

Max. cable length of a single-phase submersible pump:

$$L = \frac{U \times \Delta U}{I \times 2 \times 100 \times \left( PF \times \frac{\rho}{q} \right)} \text{ [m]}$$

where

L = Max. length of cable [m]

U = Rated voltage [V]

ΔU = Voltage drop [%]

I = Rated current of the motor [A]

ρ = Specific resistance: 0.02 [Ω mm<sup>2</sup>/m]

PF = 1

q = Cross-section of submersible drop cable [mm<sup>2</sup>]

### Example:

Voltage supply: 230V

Voltage drop: 4%

Current of the motor: 11.1 [A]

q = 1.5 mm<sup>2</sup> cable.

$$L = \frac{230 \times 4}{11.1 \times 2 \times 100 \times 1 \times \frac{0.02}{1.5}} \text{ [m]}$$

L = 32 m

A product number from the table below covers the following:

- One cable length with motor plug, packed
- 6 screws (M4) for fitting of plug
- 3 screws (M3 x 6) for fitting of cable guard to suction strainer.

Length [m]	Cross-section of leads			
	1.5 mm <sup>2</sup> Flat	2.5 mm <sup>2</sup> Round	4 mm <sup>2</sup> Round	6 mm <sup>2</sup> Round
1.5	96160869			
5	96160870			
10	96160871			
15	96160872			
20	96160873			
30	96160874			
40	96160875	96160583		
50	96160876	96160584		
60	96160877	96160585		
70	96160878	96160586		
80	96160879	96160587		
90	96160880	96160588	96160590	96160592
100	96160881	96160589	96160591	96160593

For cables with the cross-sections of leads, 2.5, 4 and 6 mm<sup>2</sup>, the cable consists of 1.5 m flat motor cable followed by a round submersible drop cable.

## SQ packages

Packages of SQ and SQE pumps including selected lengths of submersible drop cable are listed below. The length of the cable in below table are calculated according to the actual motor load of each specific pump size.

Pump type	Cable length (3 x 1.5 mm <sup>2</sup> ) [m]	Product number
SQ 1 - 65	30	96524421
SQ 1 - 80	30	96524428
SQ 1 - 80	50	96524429
SQ 1 - 140	70	96524442 *
SQ 2 - 35	15	96524423
SQ 2 - 55	10	96524430
SQ 2 - 55	15	96524431
SQ 2 - 55	30	96524432
SQ 2 - 55	60	96524433
SQ 2 - 70	30	96524434
SQ 2 - 70	60	96524436
SQ 2 - 70	80	96524435 *
SQ 2 - 85	40	96524443
SQ 2 - 85	80	96524444 *
SQ 3 - 30	30	96618723
SQ 3 - 40	15	96524426
SQ 3 - 40	30	96524427
SQ 3 - 40	30	96160577 ***
SQ 3 - 55	15	96524437
SQ 3 - 55	30	96524438
SQ 3 - 65	30	96524439
SQ 3 - 65	40	96524440
SQ 3 - 80	30	96524445
SQ 3 - 80	50	96524446
SQ 3 - 95	70	96524447 *
SQ 3 - 105	80	96524448 **
SQ 5 - 35	15	96524441
SQ 5 - 50	15	96524449
SQ 5 - 50	30	96524450
SQ 5 - 60	30	96524451
SQ 5 - 70	30	96524452
SQ 7 - 40	15	96524453

\* 3 x 2.5 mm<sup>2</sup>

\*\* 3 x 4 mm<sup>2</sup>

\*\*\* Fitted with schuko plug.



<b>V7141076</b> 0206	<b>GB</b>
Repl. V7141076 0505	

Subject to alterations.